



with ESM, ACi and iQ/iQ<sup>2</sup>-motor



The engineer's choice

**ebmpapst**

# The new generation of energy-saving fans

*Energy savings have become an important topic in almost every aspect of life. Our extended energy saving fan series, based on the energy saving motor (ESM) and the iQ-motor, offers high efficiency throughout a long service life and a significant decrease in energy consumption along with it. This is precisely what is required for refrigeration systems, such as in refrigerated and freezer cases or for condensing units.*

## **Comprehensive series**

The series of these energy saving fans includes the compact fan series of ACi 4400 as well as based on the energy saving motor (ESM), axial fans and centrifugal modules as well as the iQ-motor as an energy saving variant of the Q-motor.

Axial fans are available in sizes of 130, 172, 200, 230, 250 and 300 mm plus the compact fan ACi 4400 with the dimensions 119 x 119 x 38 mm. With their new rotors and wall rings, which have been optimised according to aerodynamic criteria, the fans now work even more quietly and require no varnish, a particularly environmentally friendly feature.

Energy saving centrifugal modules are available in sizes of 190 and 220 mm. These are especially appealing due to their compact and aerodynamically optimised design, which allows customers to install them quickly and hassle-free.

The K1G200 energy saving centrifugal module in a diagonal impeller design rounds out the ESM series. It particularly distinguishes itself due to noise-optimised and air flow-optimised performance in the medium pressure range. ebm-papst sets the benchmark here, too.

The existing series was expanded with additional versions and functions to meet new market demands. Among other things, this includes a 24 VDC design with an integrated 0-10 VDC open loop speed control and a speed monitoring output.

A 0-10 VDC open loop speed control is now possible even for the existing line-fed designs by using an ESM+ plug-in module.

This series is supplemented by the energy saving iQ-motor based on ebm-papst's GreenTech EC technology. The iQ<sup>2</sup> series further expands the offering with additional functions. Due to its dimensions and mounting options, which are identical to the Q-motor already established on the market, customers are given the possibility of a 1:1 replacement without extensive renovations.









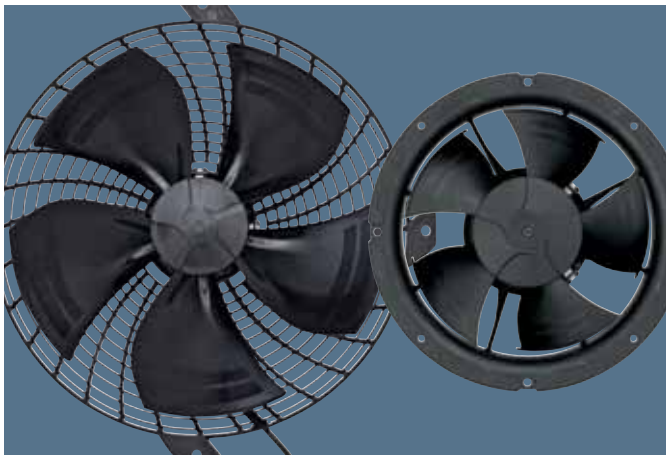
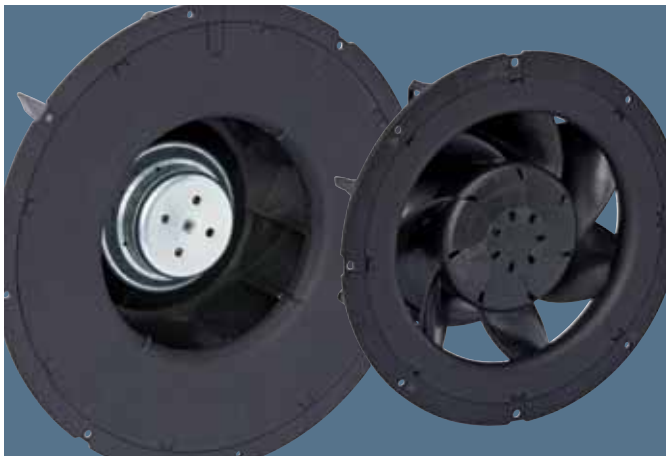

The iQ-motor can be readily installed with normal axial impellers with a 154 to 254 mm diameter.

## **Maximum efficiency**

Our fans and motors achieve a maximum motor efficiency of over 70% and thus only need 1/3 to 1/6 of the power of an otherwise normal shaded-pole motor. Higher efficiency also means lower intrinsic heating during operation at the same time, which dissipates less heat into the surrounding area. This means that less cooling power must be generated, thus resulting in additional energy savings.

## Table of contents



 The new generation of energy-saving fans	2
 Green Tech: The Green Company	4
 Energy-saving axial fans	6
 Energy-saving centrifugal modules	32
 ESM/ACi accessories	40
 ESM electrical connections	46
 iQ/iQ <sup>2</sup> -motor	48
 iQ/iQ <sup>2</sup> -motor accessories	58
 Technical parameters & scope	62
 ebm-papst representatives & subsidiaries	66

Sustainability is at the centre of our thoughts and actions. Out of conviction!

*Eco-friendliness and sustainability have always been at the core of our thoughts and actions. For decades, we have worked according to the simple but strict creed of our co-founder Gerhard Sturm: "Each new product we develop has to be better than the last one in terms of economy and ecology." GreenTech is the ultimate expression of our corporate philosophy.*

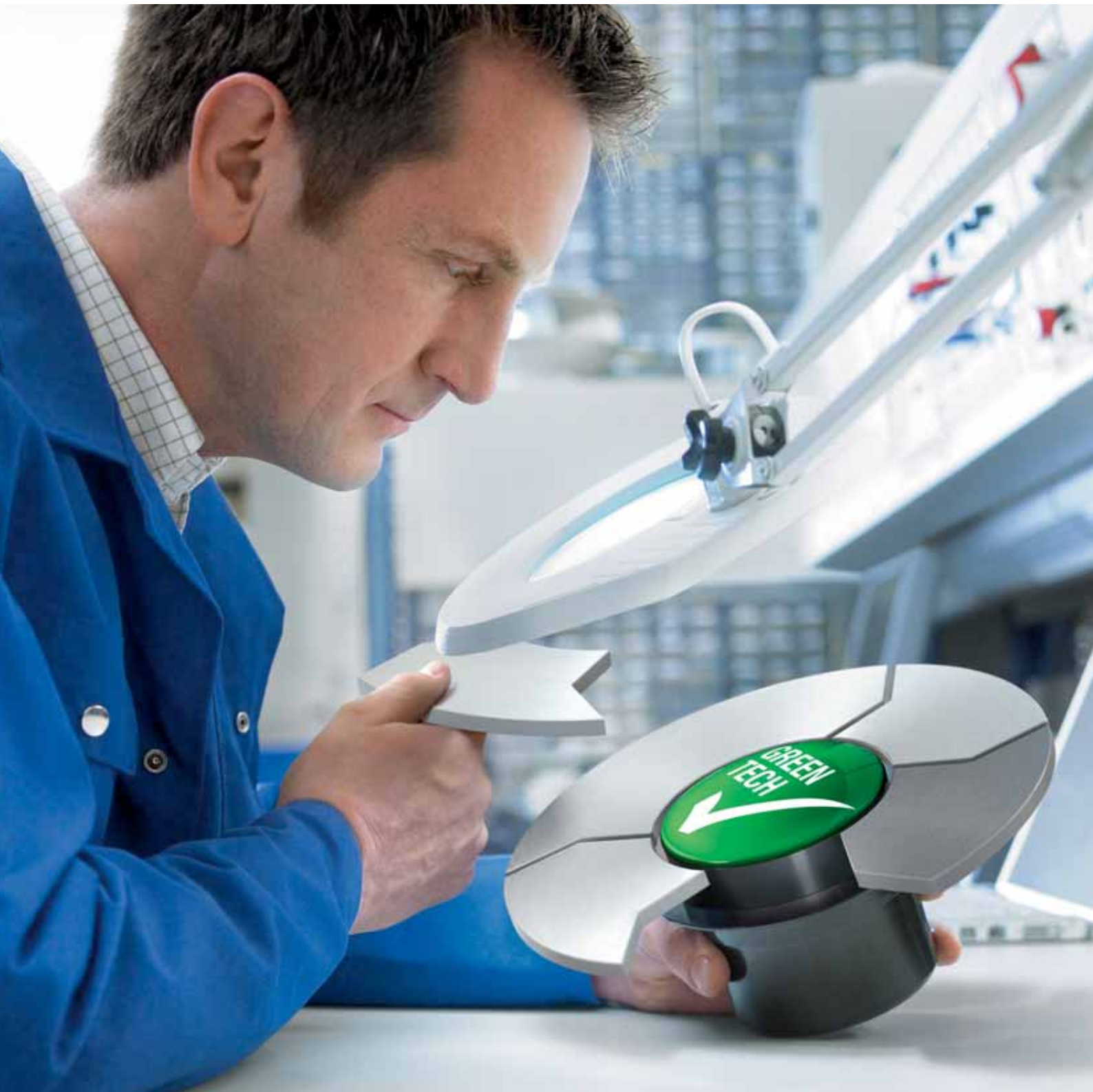



**GreenTech is pro-active development.**

Even in the design phase, the materials and processes we use are optimised for the greatest possible eco-friendliness, energy balance and – wherever possible – recyclability. We continually improve the material and performance of our products, as well as the flow and noise characteristics. At the same time, we significantly reduce energy consumption. Close co-operation with universities and scientific institutes and the professorship we endow in the area of power engineering and regenerative energies allows us to profit from the latest research findings in these fields – and at the same time ensure highly qualified young academics.

**GreenTech is eco-friendly production.**

GreenTech also stands for maximum energy efficiency in our production processes. There, the intelligent use of industrial waste heat and ground-water cooling, photovoltaics and, of course, our own cooling and ventilation technology are of the utmost importance. Our most modern plant, for instance, consumes 91% less energy than currently specified and required. In this way, our products contribute to protecting the environment, from their origin to their recyclable packaging.

**GreenTech is acknowledged and certified.**

Every step in our chain of production meets the stringent standards of environmental specialists and the public. The 2008 Environmental Prize of Baden-Wuerttemberg, the Green Award 2009, the Energy Efficiency Award 2009 of the dena – to give just a few examples – testify to this. The environmental advantage gained in the performance of the products developed from our GreenTech philosophy can also be measured in the fulfilment of the most stringent energy and environmental standards. In many instances, our products are already well below the thresholds energy legislation will impose a few years from now – several times over.

**Our customers profit from this every day.**

The heart of GreenTech is future-oriented EC technology from ebmpapst. The EC technology at the core of our most efficient motors and fans allows efficiency of up to 90%, saves energy at a very high level, significantly extends service life and makes our products maintenance-free. These values pay off not only for the environment, but every cent also pays off for the user! All ebmpapst products – even those for which GreenTech EC technology does not (yet) make sense from an application viewpoint – feature the greatest possible connection of economy and ecology.

**Series:** The existing series of energy saving axial fans was expanded by adding the ACi 4400 series and a compact fan with size 130. In addition, the ESM series is now available as a 24 VDC version with an integrated 0-10 VDC open loop speed control output and a speed monitoring signal. These control options have also become possible for line-fed designs via an additional ESM+ plug-in module.

**System:** Not just our existing shaded-pole motors were replaced by high-efficiency GreenTech EC motors for our fans, but a complete new system was developed as a whole consisting of an EC motor, impeller and wall ring. Optimum efficiency for the best possible noise behaviour was only able to be achieved by having all of the components perfectly harmonised together.

**Energy efficiency:** The energy saving motors achieve a maximum efficiency of over 70%. So they only need 1/3 to 1/6 the power of an otherwise normal shaded-pole motor. But higher efficiency also means lower intrinsic heating during operation at the same time, which dissipates less heat into the surrounding area. This results in further energy savings, since less cooling capacity needs to be put in place from the beginning.

**Easy installation:** Effort needed by the customer for installation and logistics is reduced to a minimum due to the complete system. In addition to the fan itself, only screws are needed for mounting. Further savings result from the pluggable connection line. For example, this allows installation time to be drastically reduced due to a pre-installed cable harness. The number of variants can be substantially reduced by subsequent programming as well by having different air performance levels customised accordingly – even at a later point in time. An earth wire can be omitted due to a design in protection class 2.

**Robust design (ESM):** Ten years of field experience with more than 3 million energy saving motors shows that the system is robust, maintenance-free and durable. Depending on environmental conditions, the service life usually exceeds 60,000 hours. The stator, which is hermetically sealed with a coat of plastic, is optimally protected from ambient influences. And the electronics are protected from humidity with a sealed off cover, so that IP 54 protection requirements are fulfilled. Shock loads of more than 50g have no effect on the fan due to the stable design.

**Certifications:**

ACi 4400: UL (507), VDE (EN 60950), CSA

ESM: All of the approvals required in the refrigerated case industry are present or in progress.

VDE: EN 60335-1, -2-24, -2-80, -2-89

UL 1004-1, 1004-3, UL 60730 and GOST

# The new energy-saving axial fans

ACI 4400	8
ESM Size 130, 172	10
ESM Size 200, 230, 250	14
ESM Size 300	28

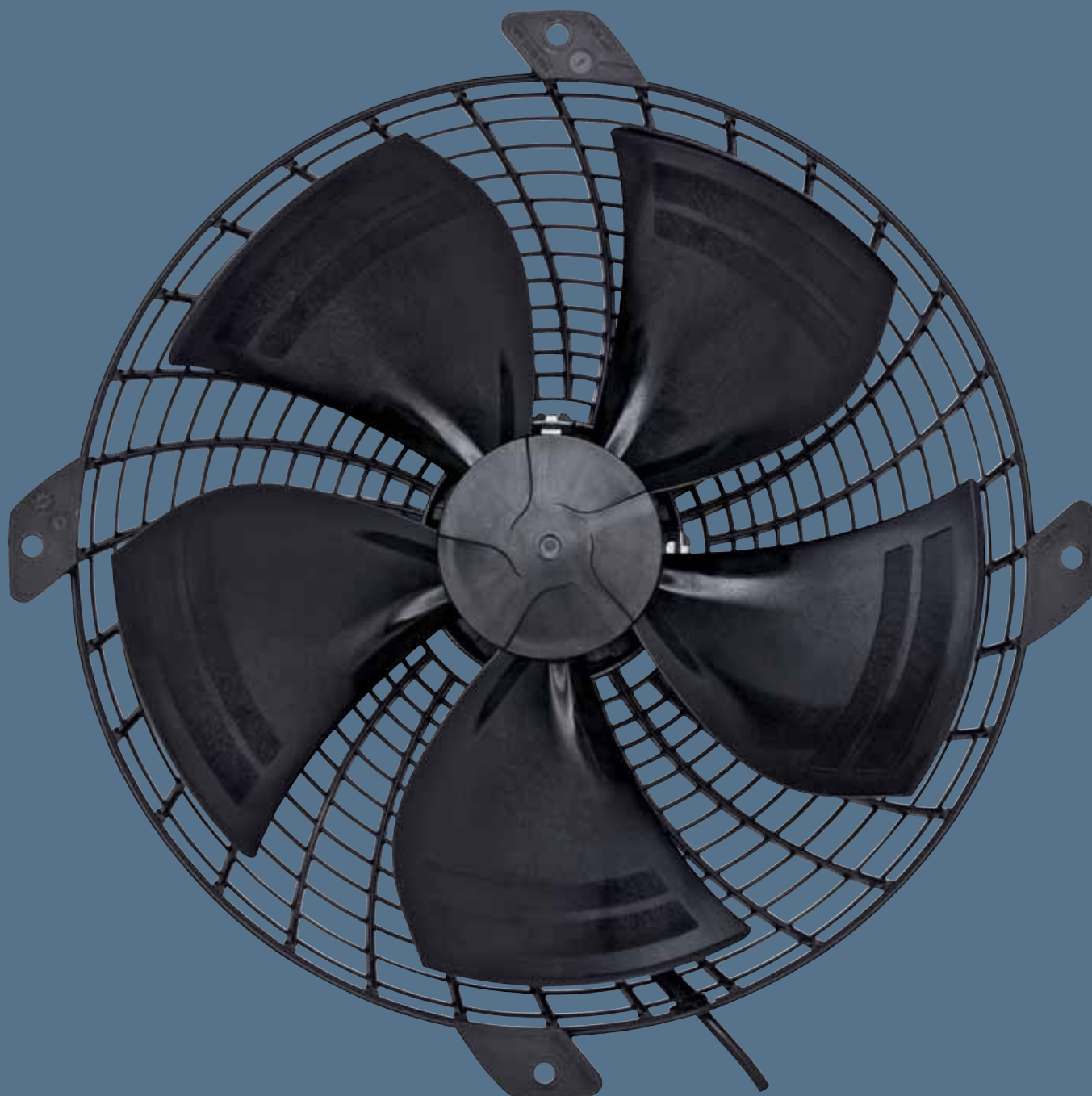

# Energy-saving axial fans

Series ACi 4400 119 x 119 x 38 mm



- **Material:** Housing: Plastic PBT  
fibreglass-reinforced  
Blade: Plastic PA,  
fibreglass-reinforced
- **Number of blades:** 5
- **Direction of air flow:** "V", exhaust over struts
- **Direction of rotation:** Clockwise, seen on rotor
- **Insulation class:** "E"
- **Mounting position:** Any
- **Condensate discharges:** None
- **Mode of operation:** Con. operation (S1)
- **Bearings:** Maintenance-free ball bearings
- **Motor protection:** Via electronics
- **Moisture protection:** Motor and circuit board are coated
- **Electrical connection:** Plug-in connection lateral
- **Protection class:** II
- **Product conforming to standard:** CE
- **Approvals:** UL (507), VDE (EN 60950), CSA

Nominal data	Curve	Nominal voltage	Nominal voltage range	Frequency	Speed/rpm	Input power	Current draw	Sound pressure level	Sound power level	Perm. amb. temp.	Mass
Type	VAC	VAC	Hz	rpm	W	mA	dB(A)	Bel(A)	°C	kg	
ACi 4420 ML	A	1~ 230	195...265	50/60	1850	1,4	17	25	4,1	-20...+75	0,25
ACi 4420 H	B	1~ 230	195...265	50/60	3000	3,3	35	39	5,1	-20...+75	0,25
ACi 4420 HH	C	1~ 230	195...265	50/60	3350	4,4	41	42	5,3	-20...+75	0,25
ACi 4410 HH	D	1~ 115	85...132	50/60	3350	4,4	82	42	5,3	-20...+75	0,25

subject to alterations

## Curves

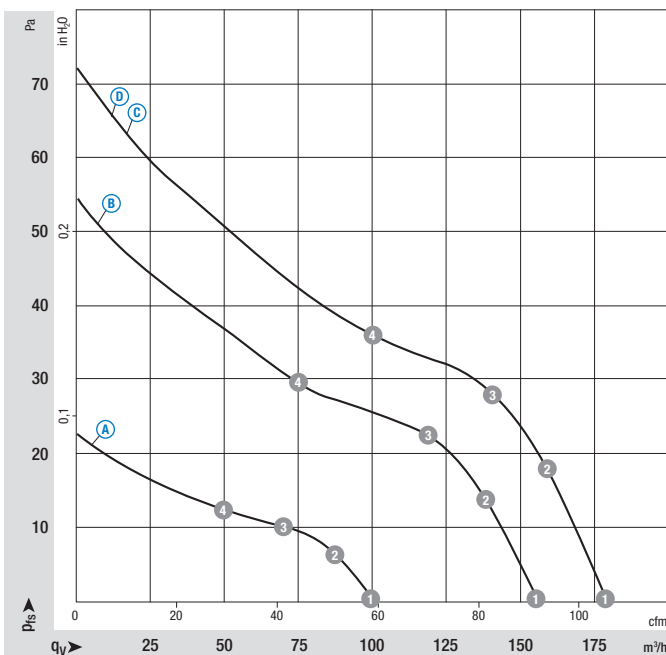

Air performance measured as per: ISO 5801, Installation category A, and without protection against accidental contact

The acoustic values given are only valid under the measurement conditions listed and may vary depending on the installation situation.

With any deviation to the standard setup, the specific values have to be checked and reviewed once installed or fitted!

For detailed information see Compact fans catalogue version 2011, p. 8-16

	n rpm	P <sub>e</sub> W	I mA
A 1	1850	1,4	17
A 2	1850	1,5	18
A 3	1850	1,6	19
A 4	1850	1,7	19
B 1	3000	3,3	35
B 2	3000	3,9	39
B 3	3000	3,9	44
B 4	3000	4,7	46
C 1	3350	4,4	41
C 2	3350	5,1	48
C 3	3350	5,7	53
C 4	3350	5,9	55
D 1	3350	4,4	82
D 2	3350	5,1	96
D 3	3350	5,7	106
D 4	3350	5,9	110



- Electr. connection:

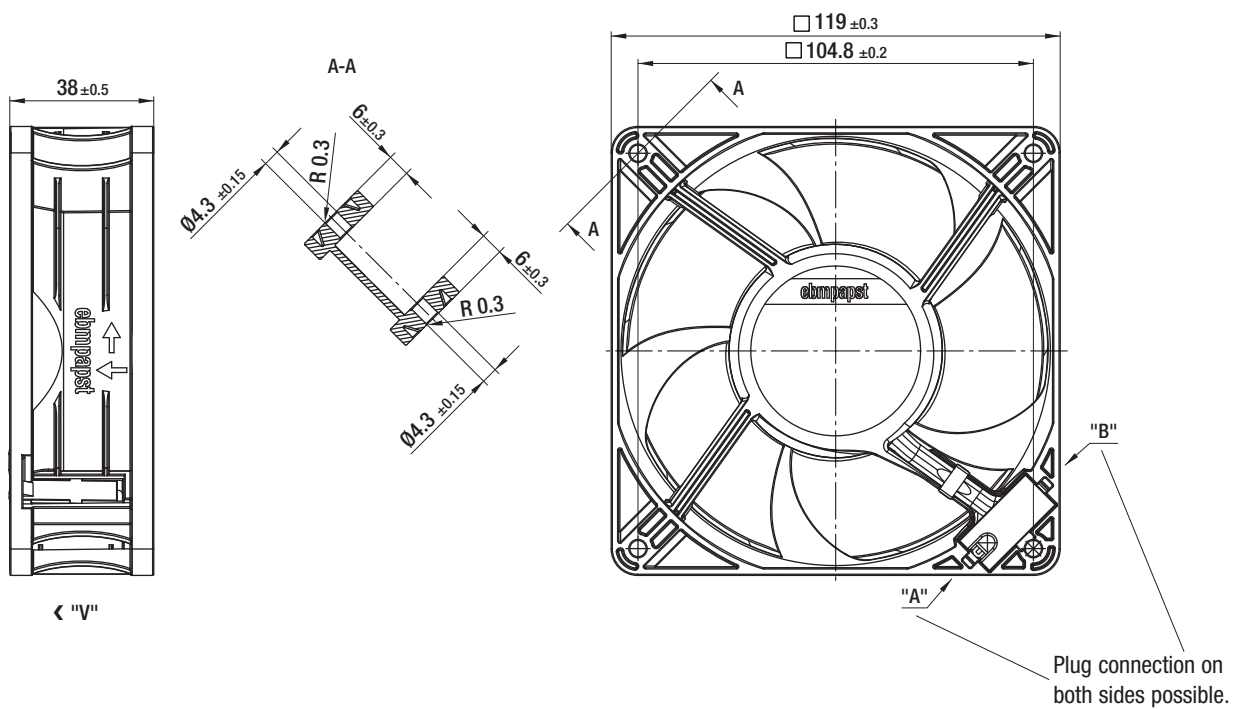
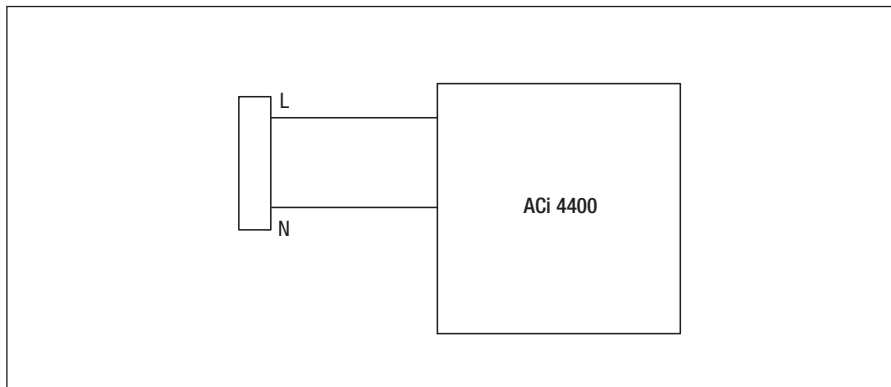

# Energy-saving axial fans

Ø 130



- **Material:** Wall ring: Plastic PP, fibreglass-reinforced; Blade: Plastic PA, fibreglass-reinforced
- **Number of blades:** 7
- **Direction of air flow:** "V", exhaust over struts
- **Direction of rotation:** Counter-clockwise, seen on rotor
- **Type of protection:** IP 54
- **Insulation class:** "B"
- **Mounting position:** Any
- **Condensate discharges:** None
- **Mode of operation:** Con. operation (S1)
- **Bearings:** Maintenance-free ball bearings
- **Motor protection:** Via electronics and TOP
- **Electrical connection:** Plug-in connection on motor side
- **Protection class:** II
- **Product conforming to standard:** CE; EN 60335-1
- **Approvals:** VDE, UL, CSA, GOST are applied for
- **Speed:** Using the programming unit, 2 speeds between  $n_{min}$  and  $n_{max}$  can be programmed.

Nominal data		Curve	Nominal voltage	Frequency	Speed/rpm <sup>(1)</sup>	Max. input power <sup>(1)</sup>	Max. current draw <sup>(1)</sup>	Max. back pressure	Perm. amb. temp.	Mass
Type	Motor	VAC	Hz	rpm	W	A	Pa	°C	kg	
<b>W1G130-AA49 -01</b>	M1G055-AI	Ⓐ 1~115	50/60	3200	24	0,38	90	-30..+60	0,75	
<b>W1G130-AA25 -01</b>	M1G055-AI	Ⓑ 1~230	50/60	3200	24	0,19	90	-30..+70	0,75	

subject to alterations

<sup>(1)</sup> Nominal data in operating point with maximum load and 115 or 230 VAC

## Curves

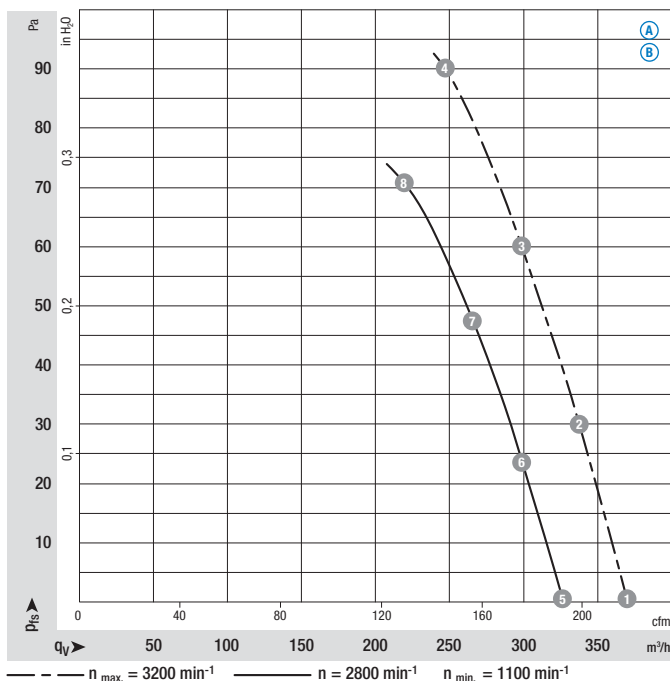

Air performance measured as per: ISO 5801, Installation category A, in ebm-papst full nozzle and without protection against accidental contact

Suction-side noise levels:  $L_{wA}$  as per ISO 13347,  $L_{pA}$  measured at 1 m distance to fan axis

The acoustic values given are only valid under the measurement conditions listed and may vary depending on the installation situation.

With any deviation to the standard setup, the specific values have to be checked and reviewed once installed or fitted!

For detailed information see page 62 ff.

	n rpm	P <sub>e</sub> W	I A	L <sub>wA</sub> dB(A)
Ⓐ 1	3200	23	0,38	63
Ⓐ 2	3200	24	0,38	61
Ⓐ 3	3200	24	0,38	60
Ⓐ 4	3200	24	0,38	63
Ⓐ 5	2800	16	0,26	60
Ⓐ 6	2800	16	0,26	58
Ⓐ 7	2800	16	0,26	57
Ⓐ 8	2800	16	0,26	60
Ⓑ 1	3200	23	0,19	63
Ⓑ 2	3200	24	0,19	61
Ⓑ 3	3200	24	0,19	60
Ⓑ 4	3200	24	0,19	63
Ⓑ 5	2800	16	0,13	60
Ⓑ 6	2800	16	0,13	58
Ⓑ 7	2800	16	0,13	57
Ⓑ 8	2800	16	0,13	60

- Electr. connection:

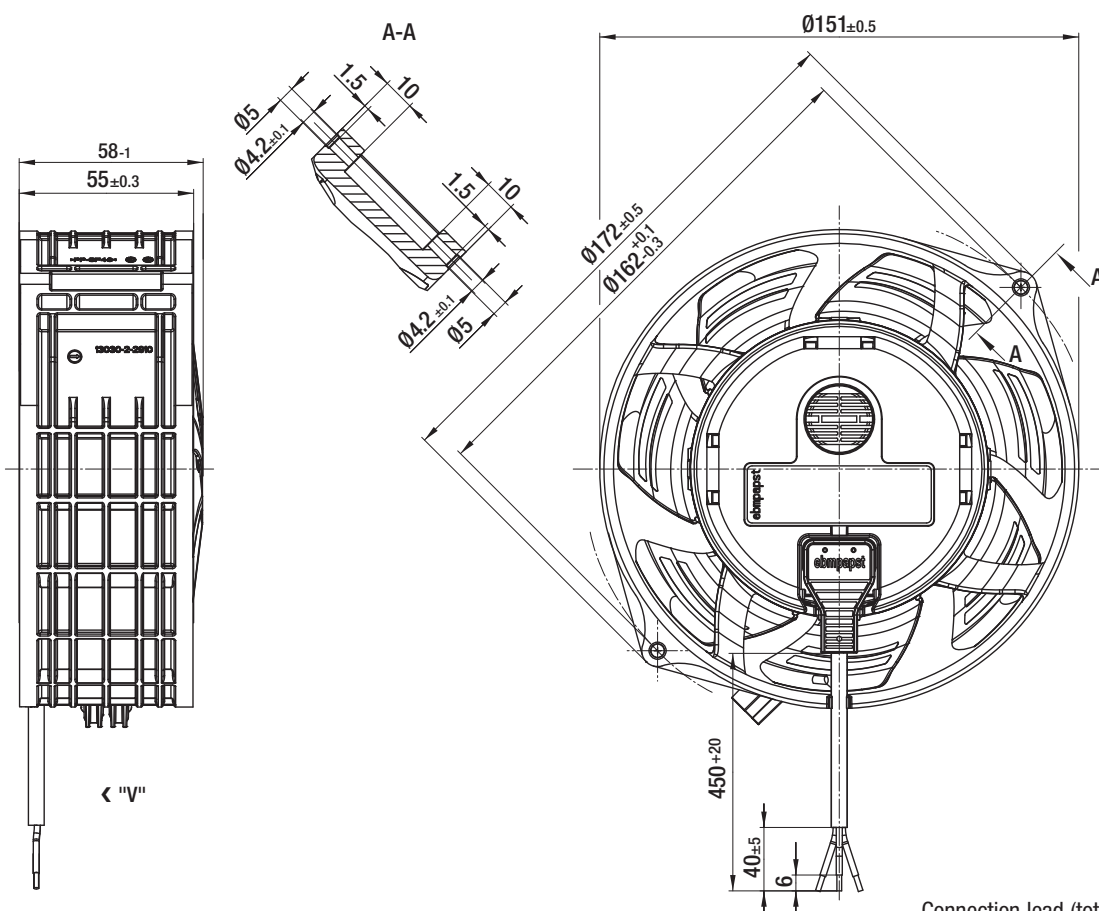
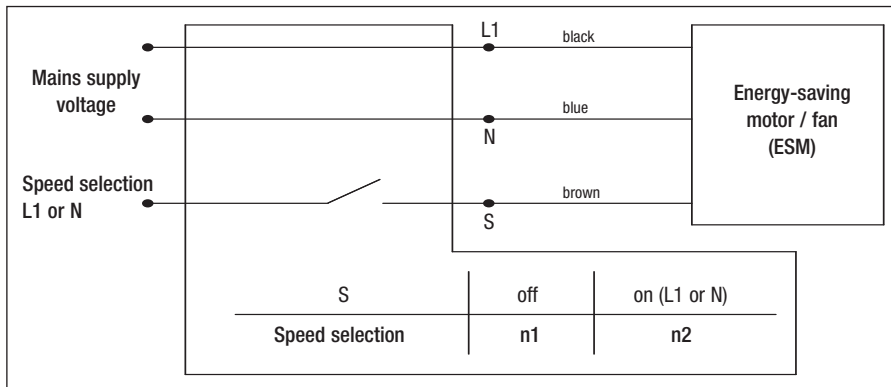

Connection lead (total length 450 mm) is fitted ex works and can be detached.

# Energy-saving axial fans

Ø 172



- **Material:** Wall ring: Plastic PP  
Blade: Plastic PA, fiberglass-reinforced
- **Number of blades:** 5
- **Direction of air flow:** "V", exhaust over struts
- **Direction of rotation:** Counter-clockwise, seen on rotor
- **Type of protection:** IP 54
- **Insulation class:** "B"
- **Mounting position:** Any
- **Condensate discharges:** None
- **Mode of operation:** Con. operation (S1)
- **Bearings:** Maintenance-free ball bearings
- **Motor protection:** Via electronics and TOP
- **Electrical connection:** Plug-in connection on motor side
- **Protection class:** II
- **Product conforming to standard:** CE
- **Approvals:** VDE, UL, CSA, GOST
- **Speed:** Using the programming unit, 2 speeds between  $n_{min}$  and  $n_{max}$  can be programmed.

Nominal data		Curve	Nominal voltage	Frequency	Speed/rpm <sup>(1)</sup>	Max. input power <sup>(1)</sup>	Max. current draw <sup>(1)</sup>	Max. back pressure	Perm. amb. temp.	Mass
Type	Motor	VAC	Hz	rpm	W	A	Pa	°C	kg	
<b>W1G172-EC95 -01</b>	M1G055-BD	Ⓐ	1~115	50/60	2500	21	0,30	60	-30..+50	0,95
<b>W1G172-EC91 -01</b>	M1G055-BD	Ⓑ	1~230	50/60	2500	22	0,18	60	-30..+50	0,95

subject to alterations

<sup>(1)</sup> Nominal data in operating point with maximum load and 115 or 230 VAC

## Curves

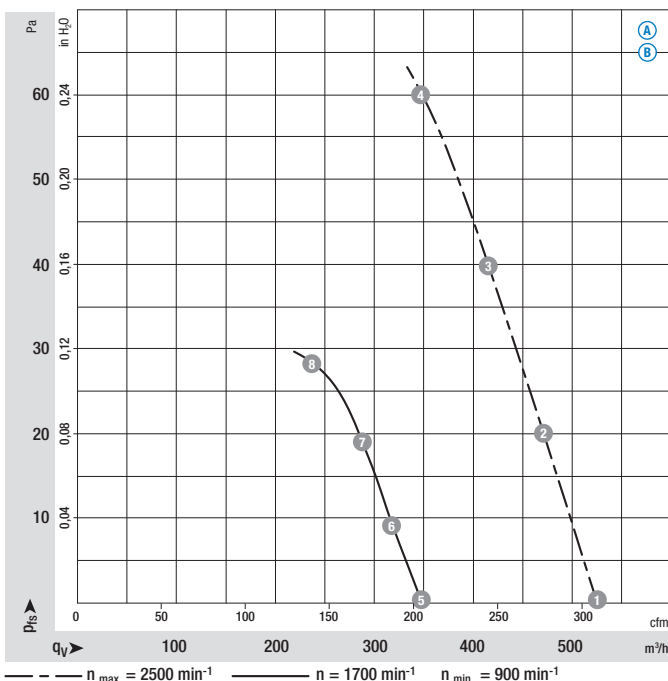

Air performance measured as per: ISO 5801, Installation category A, in ebm-papst full nozzle and without protection against accidental contact

Suction-side noise levels:  $L_{wA}$  as per ISO 13347,  $L_{pA}$  measured at 1 m distance to fan axis

The acoustic values given are only valid under the measurement conditions listed and may vary depending on the installation situation.

With any deviation to the standard setup, the specific values have to be checked and reviewed once installed or fitted!

For detailed information see page 62 ff.

	n rpm	P <sub>e</sub> W	I A	L <sub>wA</sub> dB(A)
Ⓐ 1	2500	20	0,28	62
Ⓐ 2	2500	21	0,30	63
Ⓐ 3	2500	21	0,30	63
Ⓐ 4	2500	21	0,30	63
Ⓐ 5	1700	9	0,14	54
Ⓐ 6	1700	10	0,16	53
Ⓐ 7	1700	10	0,16	53
Ⓐ 8	1700	10	0,16	54
Ⓑ 1	2500	21	0,17	62
Ⓑ 2	2500	22	0,18	63
Ⓑ 3	2500	22	0,18	63
Ⓑ 4	2500	22	0,18	63
Ⓑ 5	1700	9	0,07	54
Ⓑ 6	1700	10	0,08	53
Ⓑ 7	1700	10	0,08	53
Ⓑ 8	1700	10	0,08	54

- Electr. connection:

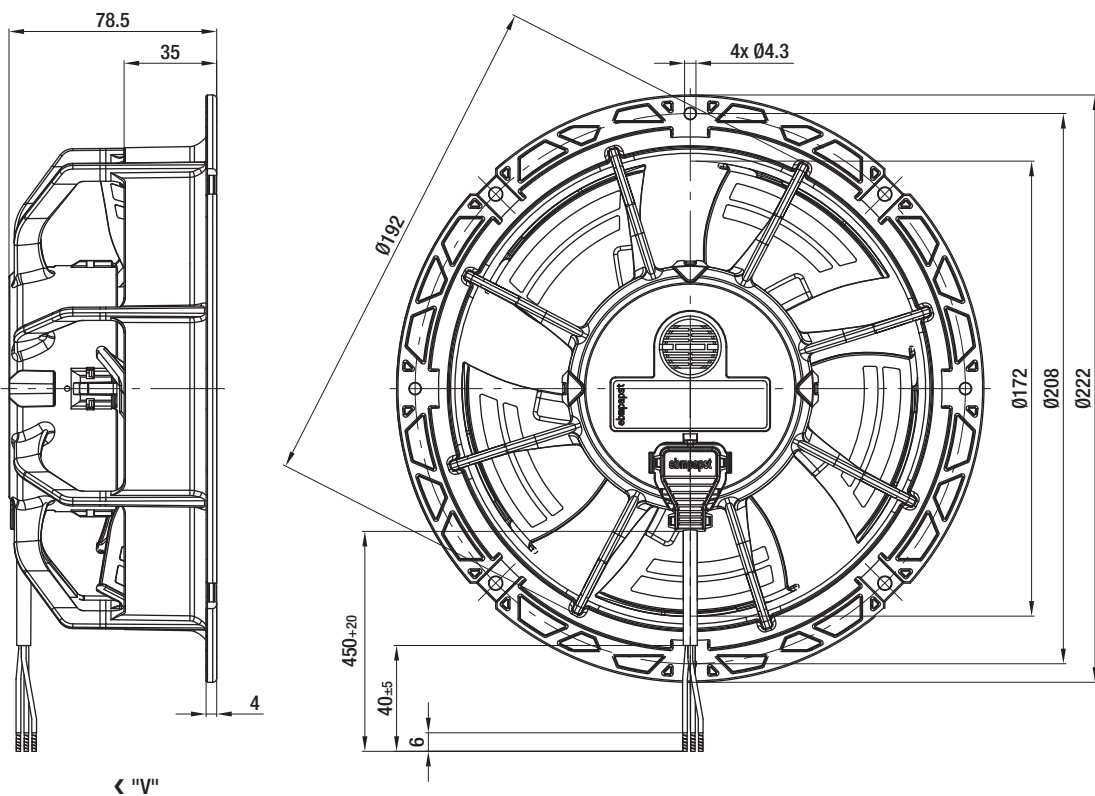
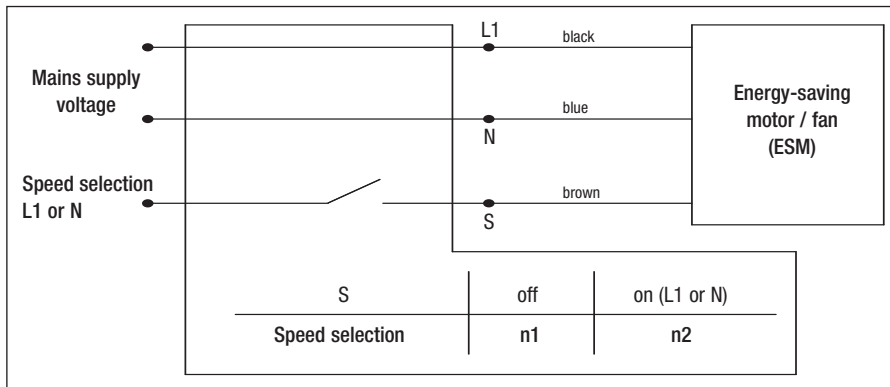

Connection lead (total length 450 mm) is fitted ex works and can be detached  
Other lengths available as accessory.

# Energy-saving axial fans

Ø 200



- **Material:** Wall ring: (A) Plastic PP  
(B) epylen  
Blade: Plastic PA,  
fibreglass-reinforced
- **Number of blades:** 5
- **Direction of air flow:** "V", exhaust over struts
- **Direction of rotation:** Counter-clockwise, seen on rotor
- **Type of protection:** IP 54
- **Insulation class:** "B"
- **Mounting position:** Any
- **Condensate discharges:** None
- **Mode of operation:** Con. operation (S1)
- **Bearings:** Maintenance-free ball bearings
- **Motor protection:** Via electronics and TOP
- **Electrical connection:** Plug-in connection on motor side
- **Protection class:** II
- **Product conforming to standard:** CE
- **Approvals:** VDE, UL, CSA, GOST
- **Speed:** Using the programming unit, 2 speeds between  $n_{min}$  and  $n_{max}$  can be programmed.

Nominal data		Curve	Nominal voltage	Frequency	Speed/rpm <sup>(1)</sup>	Max. input power <sup>(1)</sup>	Max. current draw <sup>(1)</sup>	Max. back pressure	Perm. amb. temp.	Mass
Type	Motor	VAC	Hz	rpm	W	A	Pa	°C	kg	
<b>W1G200-EC91 -27</b>	M1G055-BD	(A) 1~115	50/60	1300	8,0	0,11	23	-30..+50	1,0	
<b>W1G200-EC87 -25</b>	M1G055-BD	(B) 1~230	50/60	1300	8,0	0,07	23	-30..+50	1,0	

subject to alterations (1) Nominal data in operating point with maximum load and 115 or 230 VAC

## Curves

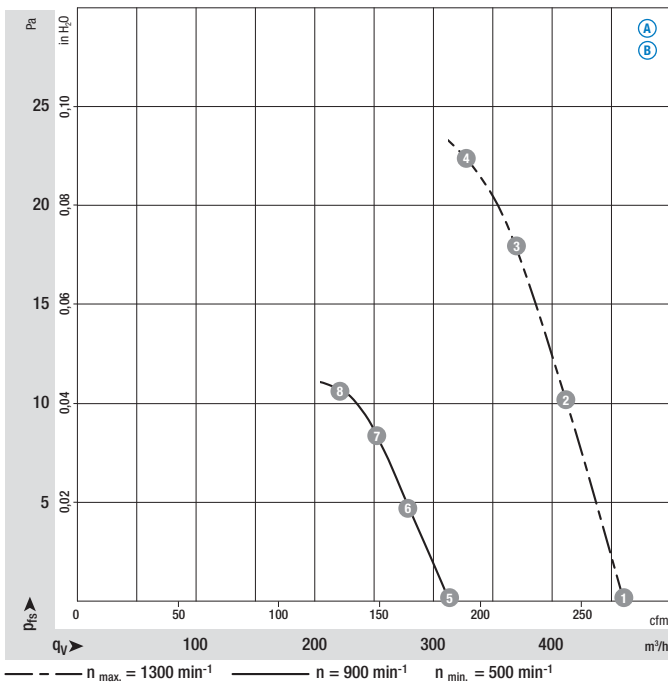

Air performance measured as per: ISO 5801, Installation category A, in ebm-papst full nozzle and without protection against accidental contact

Suction-side noise levels: L<sub>WA</sub> as per ISO 13347, L<sub>pA</sub> measured at 1 m distance to fan axis

The acoustic values given are only valid under the measurement conditions listed and may vary depending on the installation situation.

With any deviation to the standard setup, the specific values have to be checked and reviewed once installed or fitted!

For detailed information see page 62 ff.

	n rpm	P <sub>e</sub> W	I A	L <sub>WA</sub> dB(A)
(A) 1	1300	7	0,09	50
(A) 2	1300	8	0,10	49
(A) 3	1300	8	0,10	48
(A) 4	1300	8	0,11	51
(A) 5	900	3	0,05	41
(A) 6	900	4	0,05	41
(A) 7	900	4	0,05	40
(A) 8	900	4	0,05	41
(B) 1	1300	7	0,06	50
(B) 2	1300	8	0,07	49
(B) 3	1300	8	0,07	48
(B) 4	1300	8	0,07	51
(B) 5	900	3	0,03	41
(B) 6	900	4	0,04	41
(B) 7	900	4	0,04	40
(B) 8	900	4	0,04	41

– Electr. connection:

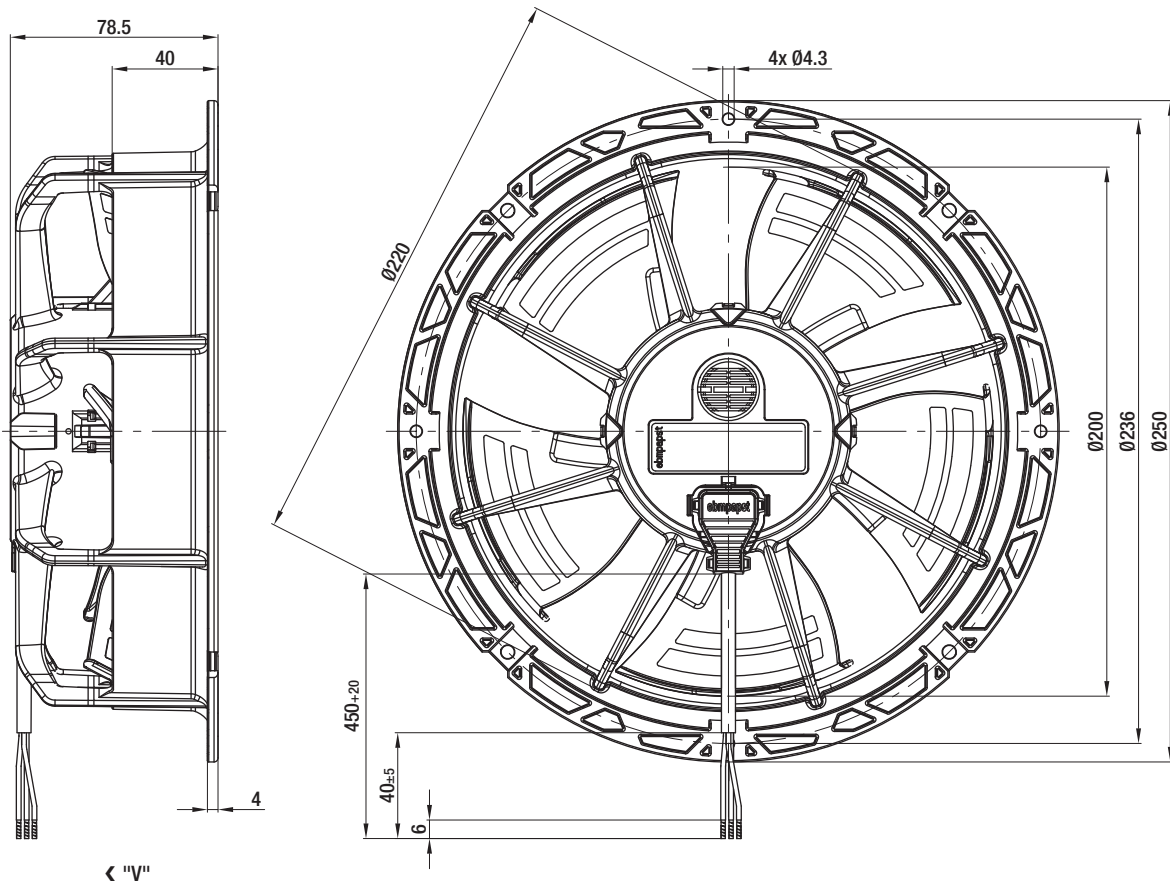
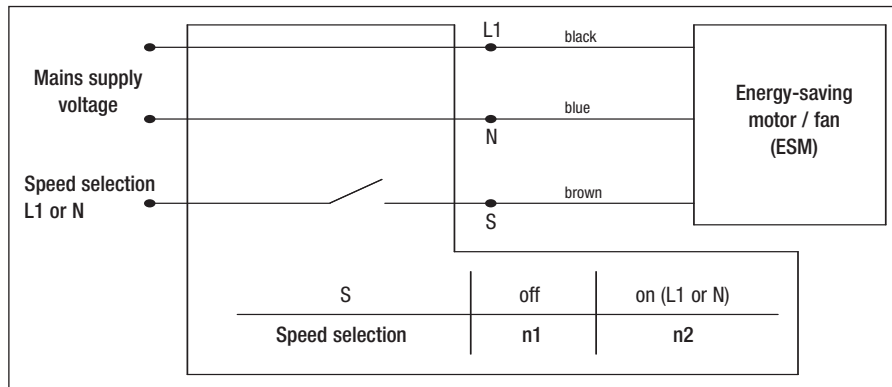

Connection lead (total length 450 mm) is fitted ex works and can be detached  
Other lengths available as accessory.

# Energy-saving axial fans

Ø 200



- **Material:** Wall ring: Plastic PP  
Blade: Plastic PA, fiberglass-reinforced
- **Number of blades:** 5
- **Direction of air flow:** "V", exhaust over struts
- **Direction of rotation:** Counter-clockwise, seen on rotor
- **Type of protection:** IP 54
- **Insulation class:** "B"
- **Mounting position:** Any
- **Condensate discharges:** None
- **Mode of operation:** Con. operation (S1)
- **Bearings:** Maintenance-free ball bearings
- **Motor protection:** Via electronics and TOP
- **Electrical connection:** Plug-in connection on motor side
- **Protection class:** II
- **Product conforming to standard:** CE
- **Approvals:** VDE, UL, CSA, GOST
- **Speed:** Using the programming unit, 2 speeds between  $n_{min}$  and  $n_{max}$  can be programmed.

Nominal data		Curve	Nominal voltage	Frequency	Speed/rpm <sup>(1)</sup>	Max. input power <sup>(1)</sup>	Max. current draw <sup>(1)</sup>	Max. back pressure	Perm. amb. temp.	Mass
Type	Motor	VAC	Hz	rpm	W	A	Pa	°C	kg	
<b>W1G200-EC95 -47</b>	M1G 055-BD	Ⓐ 1~115	50/60	2100	31	0,46	55	-30..+50	1,0	
<b>W1G200-EC91 -45</b>	M1G 055-BD	Ⓑ 1~230	50/60	2100	31	0,24	55	-30..+50	1,0	

subject to alterations

<sup>(1)</sup> Nominal data in operating point with maximum load and 115 or 230 VAC

## Curves

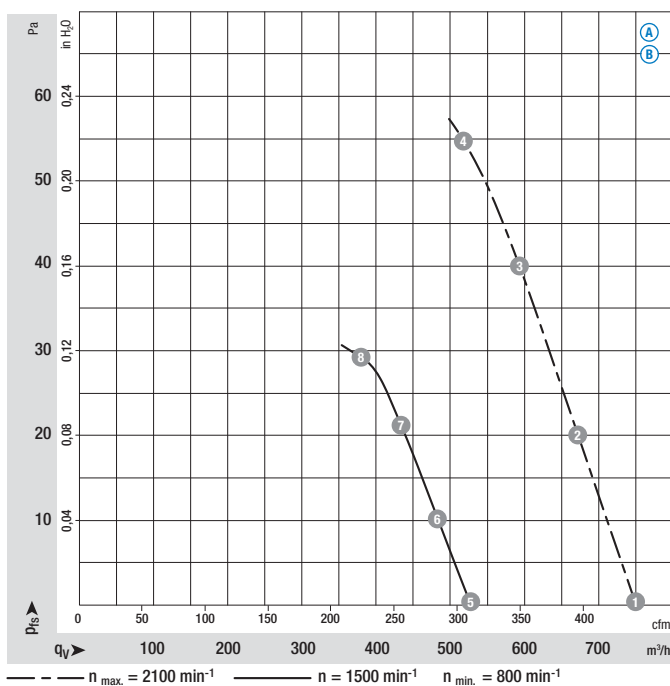

Air performance measured as per: ISO 5801, Installation category A, in ebm-papst full nozzle and without protection against accidental contact

Suction-side noise levels: L<sub>w</sub>A as per ISO 13347, L<sub>p</sub>A measured at 1 m distance to fan axis

The acoustic values given are only valid under the measurement conditions listed and may vary depending on the installation situation.

With any deviation to the standard setup, the specific values have to be checked and reviewed once installed or fitted!

For detailed information see page 62 ff.

	n rpm	P <sub>e</sub> W	I A	L <sub>w</sub> A dB(A)
Ⓐ 1	2100	28	0,42	62
Ⓐ 2	2100	30	0,45	61
Ⓐ 3	2100	31	0,46	60
Ⓐ 4	2100	31	0,46	62
Ⓐ 5	1500	14	0,22	54
Ⓐ 6	1500	15	0,22	54
Ⓐ 7	1500	16	0,26	53
Ⓐ 8	1500	16	0,26	55
Ⓑ 1	2100	29	0,22	62
Ⓑ 2	2100	30	0,23	61
Ⓑ 3	2100	31	0,24	60
Ⓑ 4	2100	31	0,24	62
Ⓑ 5	1500	14	0,11	54
Ⓑ 6	1500	16	0,12	54
Ⓑ 7	1500	16	0,13	53
Ⓑ 8	1500	16	0,13	55



– Electr. connection:

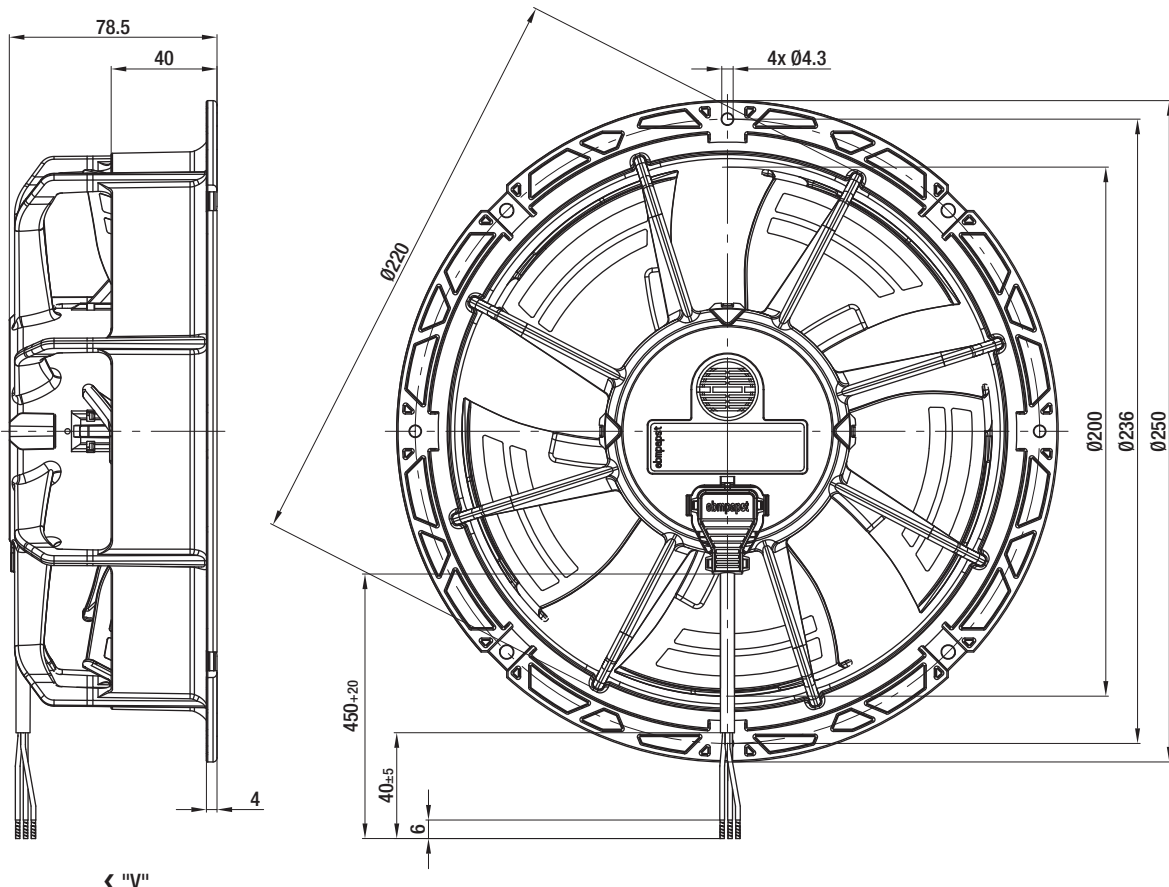
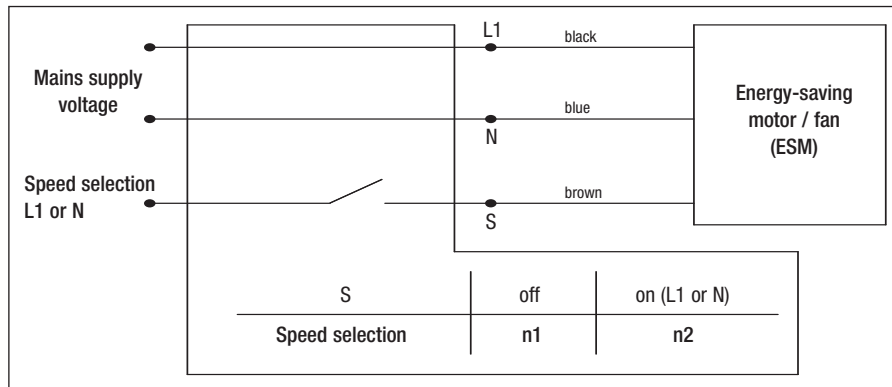

← "V"

Connection lead (total length 450 mm) is fitted ex works and can be detached  
Other lengths available as accessory.

# Energy-saving axial fans

Ø 200



- **Material:** Wall ring: epülen  
Blade: Plastic PA, fiberglass-reinforced
- **Number of blades:** 5
- **Direction of air flow:** "V", exhaust over struts
- **Direction of rotation:** Counter-clockwise, seen on rotor
- **Type of protection:** IP 54
- **Insulation class:** "B"
- **Mounting position:** Any
- **Condensate discharges:** None
- **Mode of operation:** Con. operation (S1)
- **Bearings:** Maintenance-free ball bearings
- **Motor protection:** Via electronics and TOP
- **Electrical connection:** Plug-in connection on motor side
- **Protection class:** II
- **Approvals:** VDE, UL, CSA, GOST are applied for
- **Technical features:** Control input 0-10 VDC / PWM, Tach output

Nominal data		Curve	Nominal voltage	Nominal voltage range	Speed/rpm <sup>(1)</sup>	Input power <sup>(1)</sup>	current draw <sup>(1)</sup>	Max. back pressure	Perm. amb. temp.	Mass
Type	Motor	VDC	VDC	rpm	W	A	Pa	°C	kg	
<b>W1G200-EF41 -01</b>	M1G 055-BD	Ⓐ	24	16-28	1550	11	0,50	30	-30..+50	1,0
<b>W1G200-EF01 -01</b>	M1G 055-BD	Ⓑ	24	16-28	2130	29	1,50	55	-30..+50	1,0

subject to alterations

<sup>(1)</sup> Nominal data running at free air.

## Curves

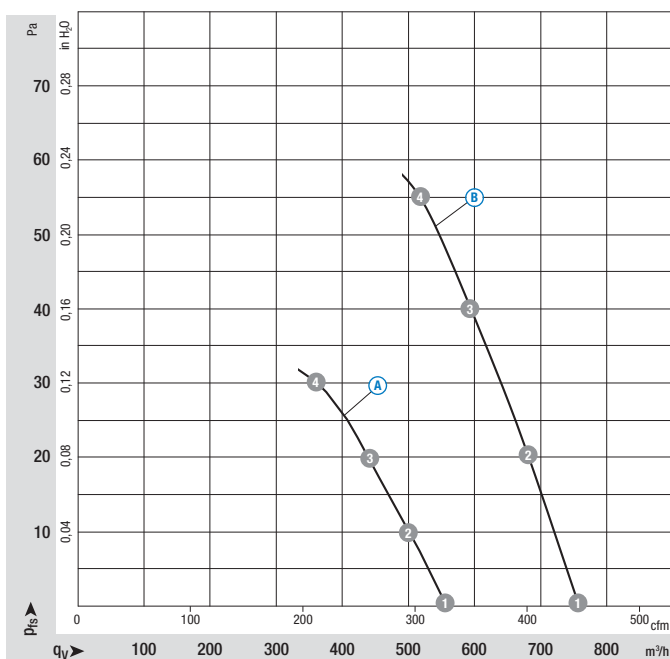

Air performance measured as per: ISO 5801, Installation category A, in ebm-papst full nozzle and without protection against accidental contact

Suction-side noise levels: L<sub>WA</sub> as per ISO 13347, L<sub>pA</sub> measured at 1 m distance to fan axis

The acoustic values given are only valid under the measurement conditions listed and may vary depending on the installation situation.

With any deviation to the standard setup, the specific values have to be checked and reviewed once installed or fitted!

For detailed information see page 62 ff.

	n rpm	P <sub>e</sub> W	I A	L <sub>WA</sub> dB(A)
Ⓐ 1	1550	11	0,50	54
Ⓐ 2	1530	11	0,50	53
Ⓐ 3	1510	11	0,51	52
Ⓐ 4	1515	11	0,51	55
Ⓑ 1	2130	29	1,50	62
Ⓑ 2	2085	30	1,56	62
Ⓑ 3	2050	31	1,61	61
Ⓑ 4	2050	31	1,62	59

- Electr. connection:

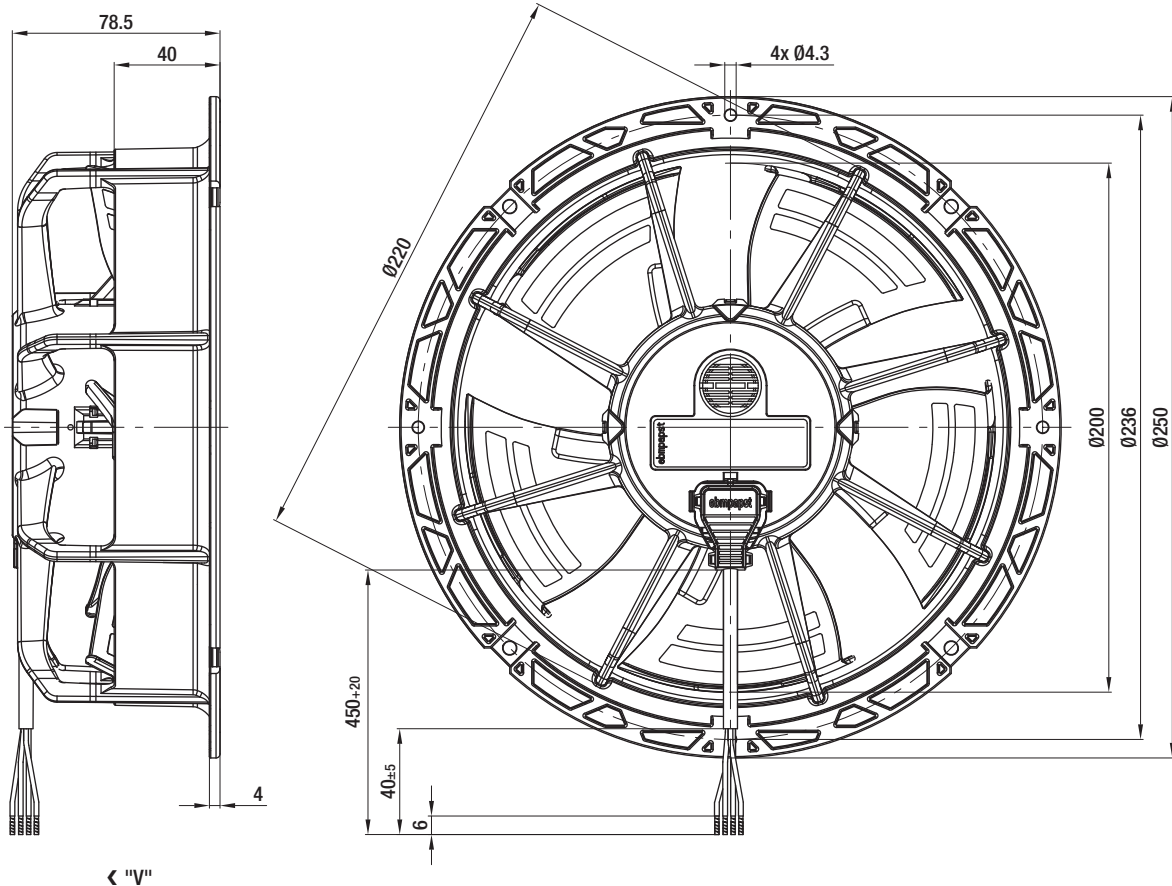
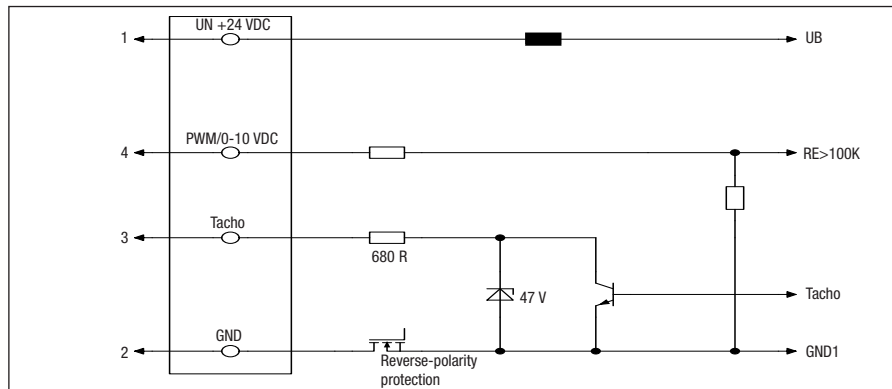

← "V"

Connection lead (total length 450 mm) is fitted ex works and can be detached  
Other lengths available as accessory.

# Energy-saving axial fans

Ø 200



- **Material:** Wall ring: epülen  
Blade: Plastic PA, fibreglass-reinforced
- **Number of blades:** 5
- **Direction of air flow:** "V", exhaust over struts
- **Direction of rotation:** Counter-clockwise, seen on rotor
- **Type of protection:** IP 54
- **Insulation class:** "B"
- **Mounting position:** Any
- **Condensate discharges:** None
- **Mode of operation:** Con. operation (S1)
- **Bearings:** Maintenance-free ball bearings
- **Motor protection:** Via electronics and TOP
- **Electrical connection:** Plug-in connection on motor side
- **Protection class:** II
- **Product conforming to standard:** CE; EN 60335-1
- **Approvals:** VDE, UL, CSA, GOST are applied for
- **Technical features:** Control input 0-10 VDC / PWM, Output 10 VDC max. 1.1 mA, Tach output

Nominal data		Curve	Nominal voltage	Frequency	Speed/rpm <sup>(1)</sup>	Max. input power <sup>(1)</sup>	Max. current draw <sup>(1)</sup>	Max. back pressure	Perm. amb. temp.	Mass
Type	Motor	VAC	Hz	rpm	W	A	Pa	°C	kg	
<b>W1G200-EC87 -A2</b>	M1G055-BD	Ⓐ	1~ 230	50/60	1300	8	0,07	23	-30..+50	1,0
<b>W1G200-EC91 -A4</b>	M1G055-BD	Ⓑ	1~ 230	50/60	2100	31	0,24	55	-30..+50	1,0

subject to alterations

<sup>(1)</sup> Nominal data in operating point with maximum load and 115 or 230 VAC

## Curves

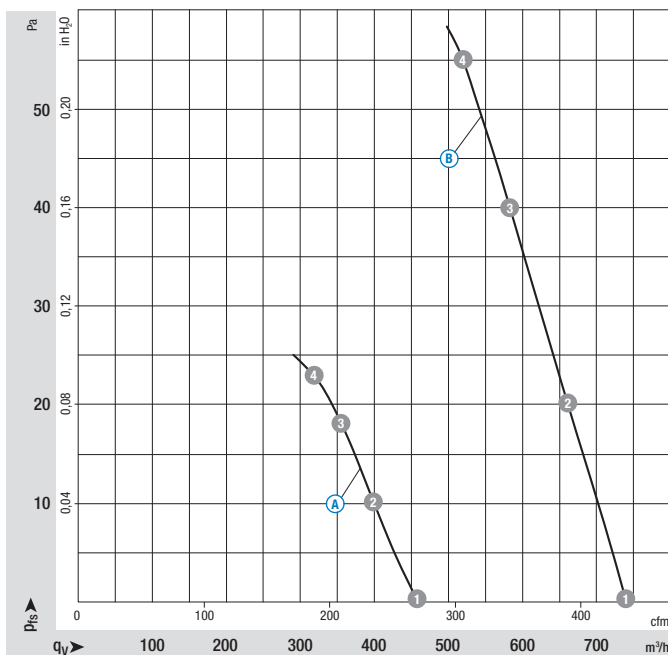

Air performance measured as per: ISO 5801, Installation category A, in ebm-papst full nozzle and without protection against accidental contact

Suction-side noise levels: L<sub>WA</sub> as per ISO 13347, L<sub>pA</sub> measured at 1 m distance to fan axis

The acoustic values given are only valid under the measurement conditions listed and may vary depending on the installation situation.

With any deviation to the standard setup, the specific values have to be checked and reviewed once installed or fitted!

For detailed information see page 62 ff.

	n rpm	P <sub>e</sub> W	I A	L <sub>WA</sub> dB(A)
Ⓐ 1	1300	7,0	0,06	50
Ⓐ 2	1300	8,0	0,07	49
Ⓐ 3	1300	8,0	0,07	48
Ⓐ 4	1300	8,0	0,07	48
Ⓑ 1	2100	29	0,23	62
Ⓑ 2	2100	30	0,24	62
Ⓑ 3	2100	31	0,24	60
Ⓑ 4	2100	31	0,24	59

- Electr. connection:

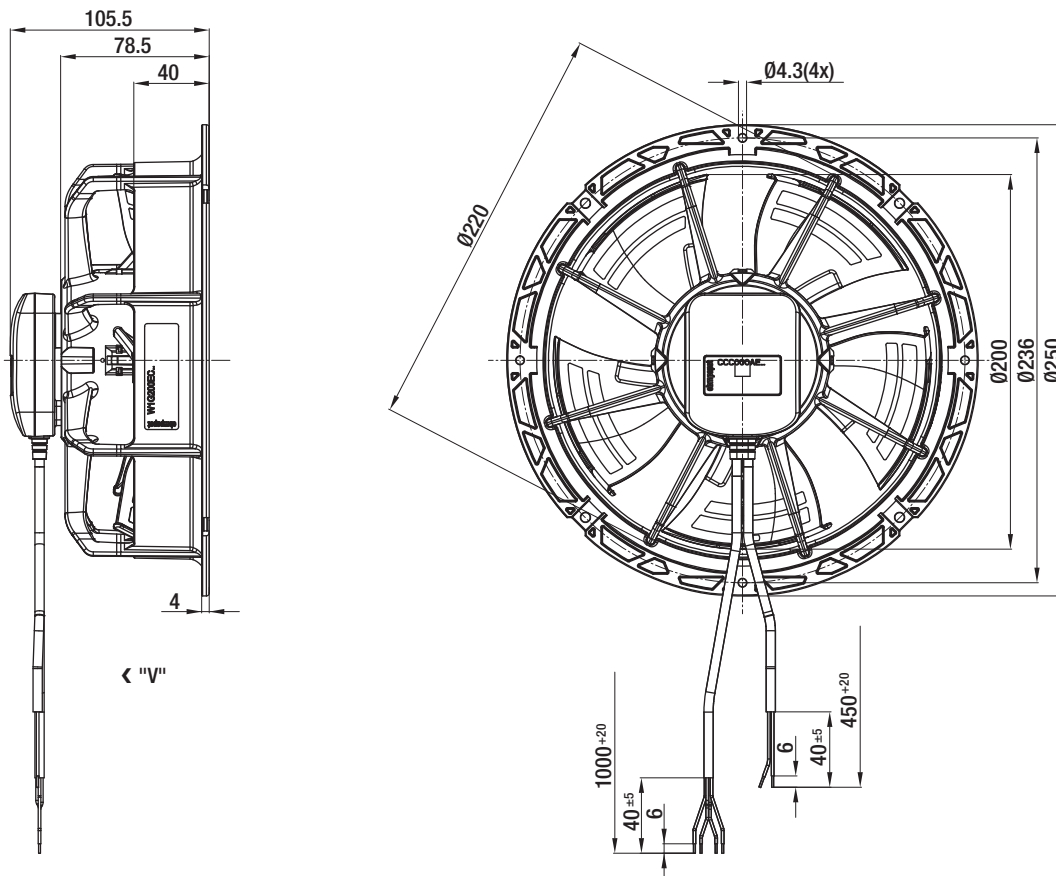
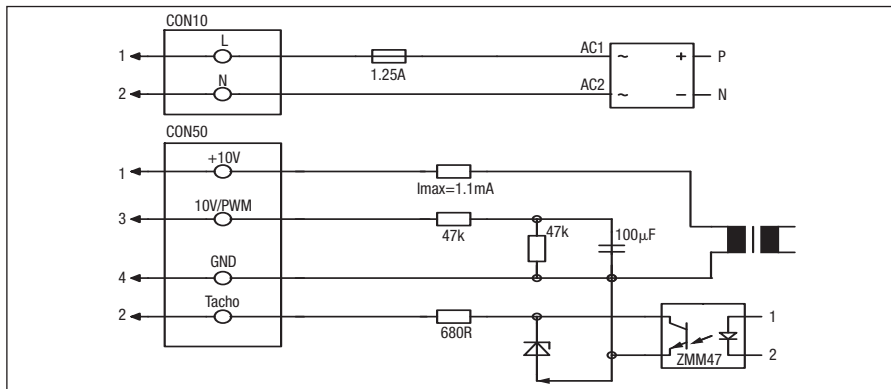

# Energy-saving axial fans

Ø 200

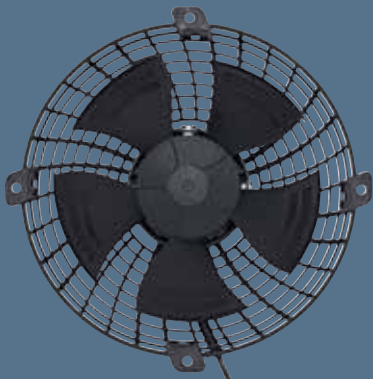

- **Material:** Blade: Plastic PA, fibreglass-reinforced  
Guard grille: epylen
- **Number of blades:** 5
- **Direction of air flow:** "A", intake over guard grille
- **Direction of rotation:** Counter-clockwise, seen on rotor
- **Type of protection:** IP 54
- **Insulation class:** "B"
- **Mounting position:** Any
- **Condensate discharges:** None
- **Mode of operation:** Con. operation (S1)
- **Bearings:** Maintenance-free ball bearings
- **Motor protection:** Via electronics and TOP
- **Electrical connection:** Plug-in connection on motor side
- **Protection class:** II
- **Product conforming to standard:** CE
- **Approvals:** VDE, UL, CSA, GOST
- **Speed:** Using the programming unit, 2 speeds between  $n_{min}$  and  $n_{max}$  can be programmed.

Nominal data		Curve	Nominal voltage	Frequency	Speed/rpm <sup>(1)</sup>	Max. input power <sup>(1)</sup>	Max. current draw <sup>(1)</sup>	Max. back pressure	Perm. amb. temp.	Mass
Type	Motor	VAC	Hz	rpm	W	A	Pa	°C	kg	
<b>S1G 200-CA95 -02</b>	M1G 055-BD	Ⓐ 1~ 115	50/60	2000	31	0,43	45	-30..+50	0,95	
<b>S1G 200-CA91 -02</b>	M1G 055-BD	Ⓑ 1~ 230	50/60	2000	34	0,26	45	-30..+50	0,95	

subject to alterations

<sup>(1)</sup> Nominal data in operating point with maximum load and 115 or 230 VAC

## Curves

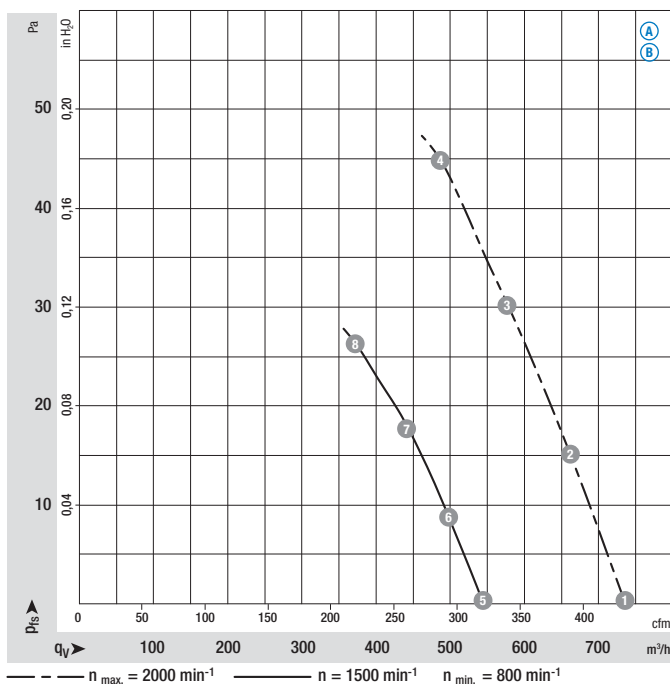

Air performance measured as per: ISO 5801, Installation category A, in ebm-papst short nozzle and with protection against accidental contact

Suction-side noise levels:  $L_{wA}$  as per ISO 13347,  $L_pA$  measured at 1 m distance to fan axis

The acoustic values given are only valid under the measurement conditions listed and may vary depending on the installation situation.

With any deviation to the standard setup, the specific values have to be checked and reviewed once installed or fitted!

For detailed information see page 62 ff.

	n rpm	P <sub>e</sub> W	I A	L <sub>wA</sub> dB(A)
Ⓐ 1	2000	30	0,43	64
Ⓐ 2	2000	30	0,43	64
Ⓐ 3	2000	30	0,43	63
Ⓐ 4	2000	31	0,43	64
Ⓐ 5	1500	17	0,28	59
Ⓐ 6	1500	18	0,28	58
Ⓐ 7	1500	19	0,28	58
Ⓐ 8	1500	20	0,28	59
Ⓑ 1	2000	32	0,24	64
Ⓑ 2	2000	33	0,25	64
Ⓑ 3	2000	33	0,25	63
Ⓑ 4	2000	34	0,26	64
Ⓑ 5	1500	18	0,16	59
Ⓑ 6	1500	19	0,16	58
Ⓑ 7	1500	19	0,16	58
Ⓑ 8	1500	20	0,16	59

– Electr. connection:

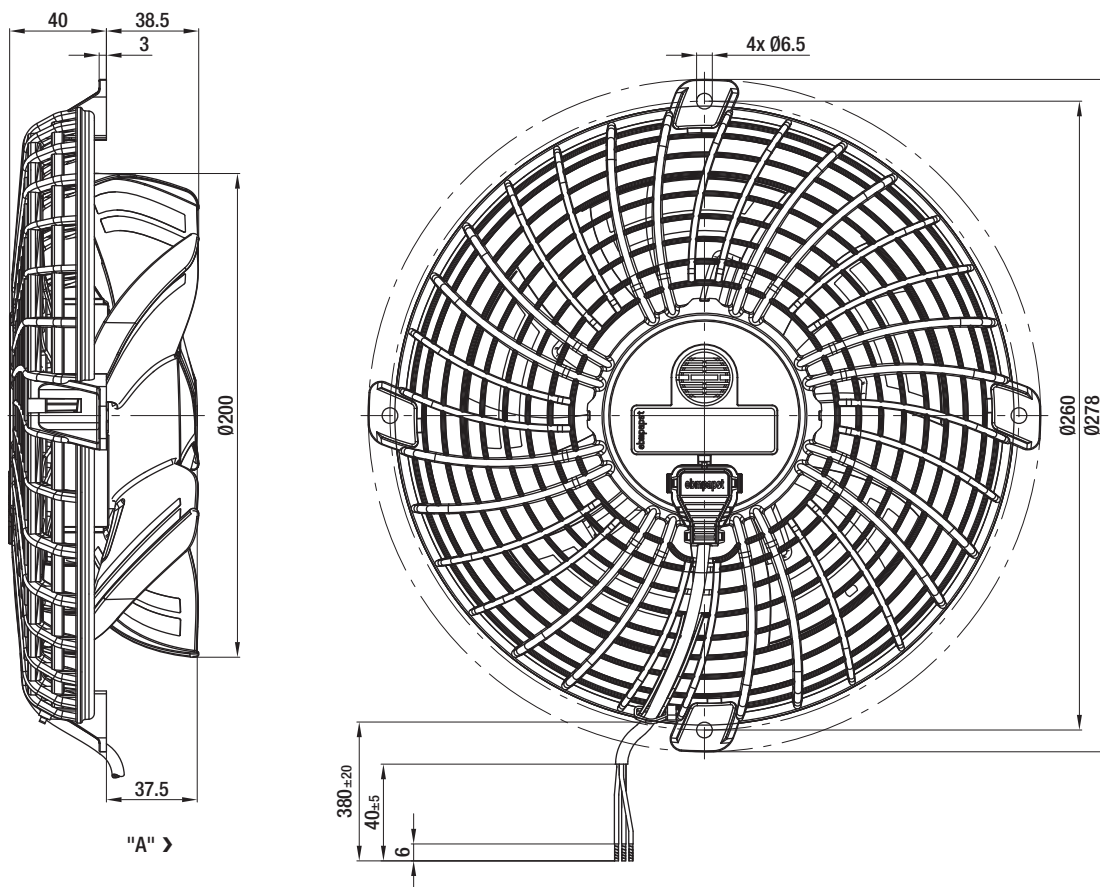
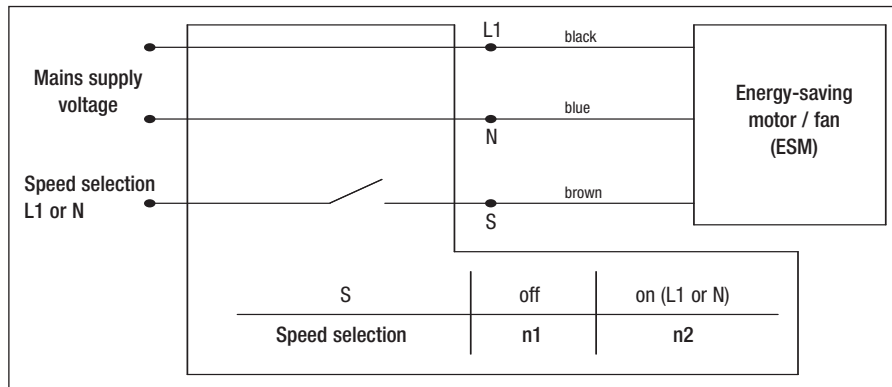

Connection lead (total length 450 mm) is fitted ex works and can be detached  
Other lengths available as accessory.

# Energy-saving axial fans

Ø 230



- **Material:** Wall ring: Plastic PP  
Blade: Plastic PA, fiberglass-reinforced
- **Number of blades:** 5
- **Direction of air flow:** "V", exhaust over struts
- **Direction of rotation:** Counter-clockwise, seen on rotor
- **Type of protection:** IP 54
- **Insulation class:** "B"
- **Mounting position:** Any
- **Condensate discharges:** None
- **Mode of operation:** Con. operation (S1)
- **Bearings:** Maintenance-free ball bearings
- **Motor protection:** Via electronics and TOP
- **Electrical connection:** Plug-in connection on motor side
- **Protection class:** II
- **Product conforming to standard:** CE
- **Approvals:** VDE, UL, CSA, GOST
- **Speed:** Using the programming unit, 2 speeds between  $n_{min}$  and  $n_{max}$  can be programmed.

Nominal data		Curve	Nominal voltage	Frequency	Speed/rpm <sup>(1)</sup>	Max. input power <sup>(1)</sup>	Max. current draw <sup>(1)</sup>	Max. back pressure	Perm. amb. temp.	Mass
Type	Motor	VAC	Hz	rpm	W	A	Pa	°C	kg	
<b>W1G230-EB97 -01</b>	M1G 055-BD	Ⓐ	1~ 115	50/60	1500	23	0,35	36	-30..+50	1,05
<b>W1G230-EB89 -01</b>	M1G 055-BD	Ⓑ	1~ 230	50/60	1500	26	0,20	36	-30..+50	1,05

subject to alterations

<sup>(1)</sup> Nominal data in operating point with maximum load and 115 or 230 VAC

## Curves

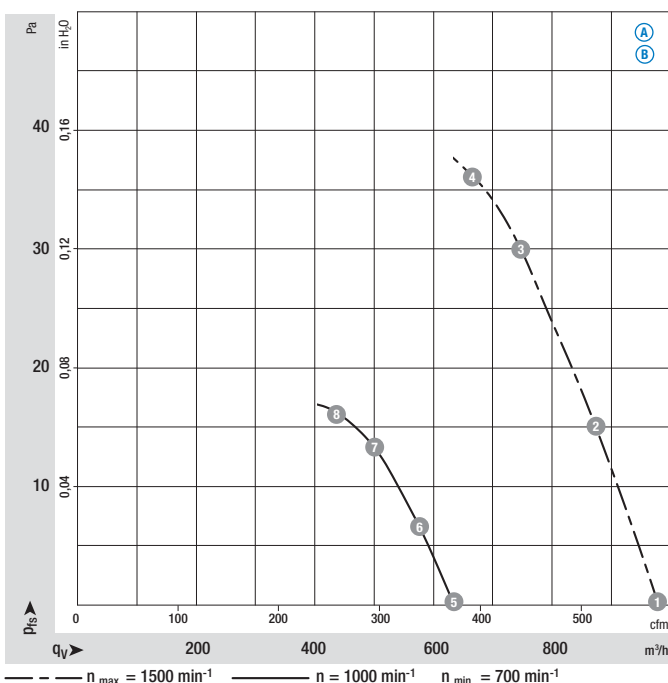

Air performance measured as per: ISO 5801, Installation category A, in ebm-papst full nozzle and without protection against accidental contact

Suction-side noise levels:  $L_{wA}$  as per ISO 13347,  $L_pA$  measured at 1 m distance to fan axis

The acoustic values given are only valid under the measurement conditions listed and may vary depending on the installation situation.

With any deviation to the standard setup, the specific values have to be checked and reviewed once installed or fitted!

For detailed information see page 62 ff.

	n rpm	P <sub>e</sub> W	I A	L <sub>wA</sub> dB(A)
Ⓐ 1	1500	23	0,35	58
Ⓐ 2	1500	23	0,35	58
Ⓐ 3	1500	23	0,35	58
Ⓐ 4	1500	23	0,35	57
Ⓐ 5	1000	9	0,15	48
Ⓐ 6	1000	10	0,16	48
Ⓐ 7	1000	10	0,16	48
Ⓐ 8	1000	10	0,16	48
Ⓑ 1	1500	24	0,19	58
Ⓑ 2	1500	25	0,19	58
Ⓑ 3	1500	25	0,19	58
Ⓑ 4	1500	26	0,20	57
Ⓑ 5	1000	10	0,09	48
Ⓑ 6	1000	11	0,09	48
Ⓑ 7	1000	11	0,10	48
Ⓑ 8	1000	11	0,10	48



– Electr. connection:

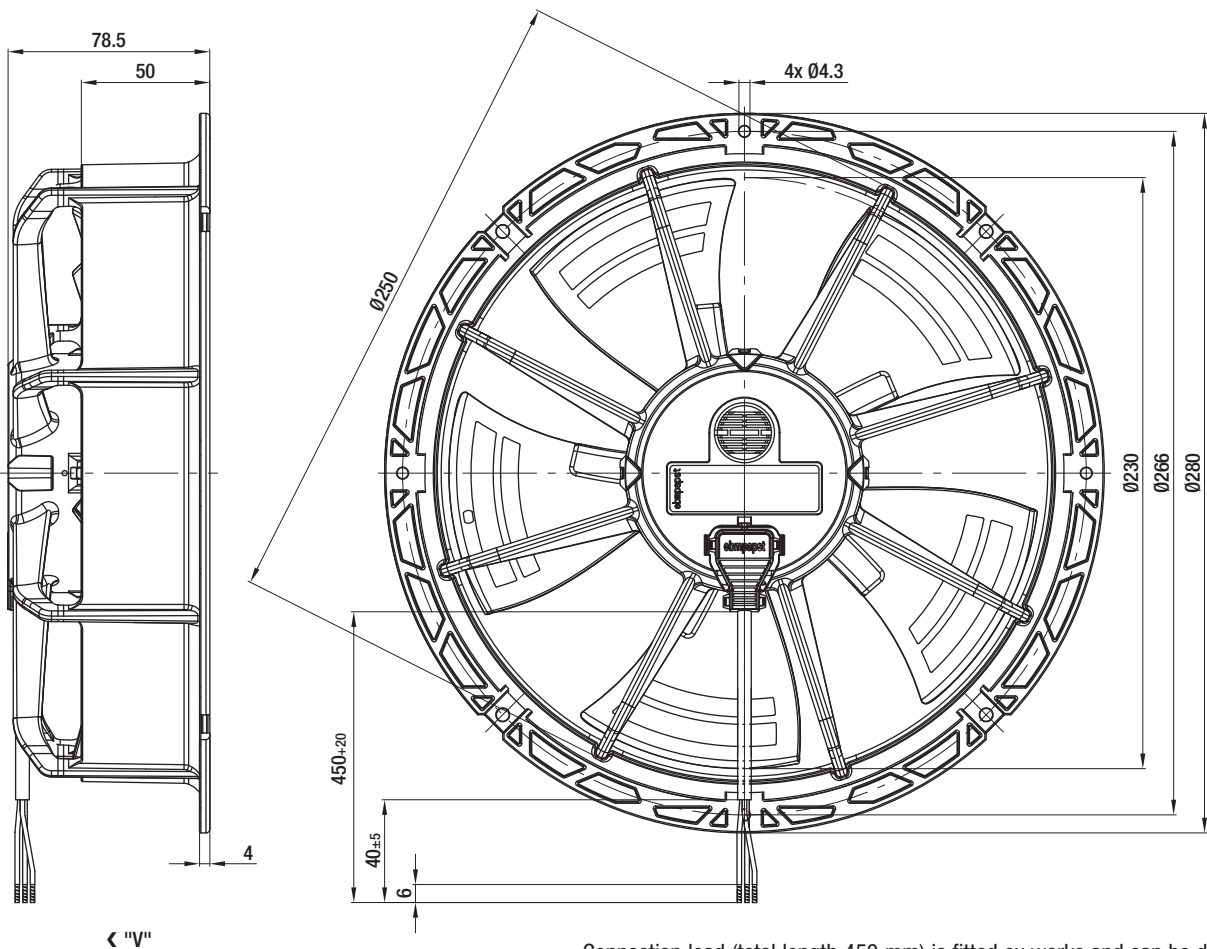
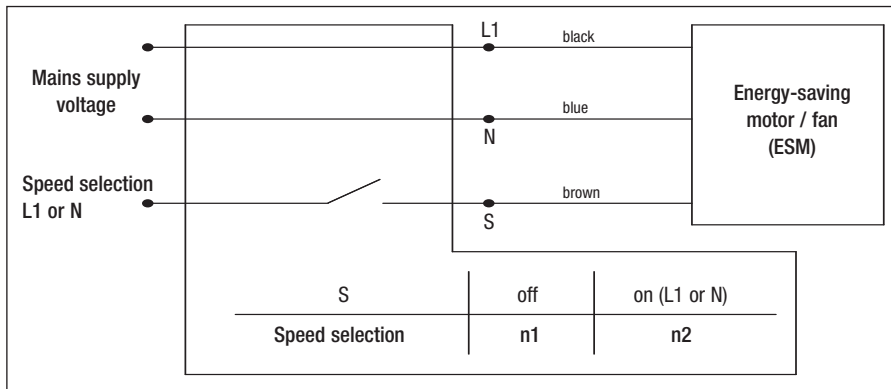

Connection lead (total length 450 mm) is fitted ex works and can be detached  
Other lengths available as accessory.

# Energy-saving axial fans

Ø 250



- **Material:** Wall ring: Plastic PP  
Blade: Plastic PA, fiberglass-reinforced
- **Number of blades:** 5
- **Direction of air flow:** "V", exhaust over struts
- **Direction of rotation:** Counter-clockwise, seen on rotor
- **Type of protection:** IP 54
- **Insulation class:** "B"
- **Mounting position:** Any
- **Condensate discharges:** None
- **Mode of operation:** Con. operation (S1)
- **Bearings:** Maintenance-free ball bearings
- **Motor protection:** Via electronics and TOP
- **Electrical connection:** Plug-in connection on motor side
- **Protection class:** II
- **Product conforming to standard:** CE
- **Approvals:** VDE, UL, CSA, GOST
- **Speed:** Using the programming unit, 2 speeds between  $n_{min}$  and  $n_{max}$  can be programmed.

Nominal data		Curve	Nominal voltage	Frequency	Speed/rpm <sup>(1)</sup>	Max. input power <sup>(1)</sup>	Max. current draw <sup>(1)</sup>	Max. back pressure	Perm. amb. temp.	Mass
Type	Motor	VAC	Hz	rpm	W	A	Pa	°C	kg	
<b>W1G250-BB21 -01</b>	M1G 055-BI	Ⓐ 1~115	50/60	1700	32	0,47	40	-30..+50	1,55	
<b>W1G250-BB17 -01</b>	M1G 055-BI	Ⓑ 1~230	50/60	1700	32	0,24	40	-30..+50	1,55	

subject to alterations

<sup>(1)</sup> Nominal data in operating point with maximum load and 115 or 230 VAC

## Curves

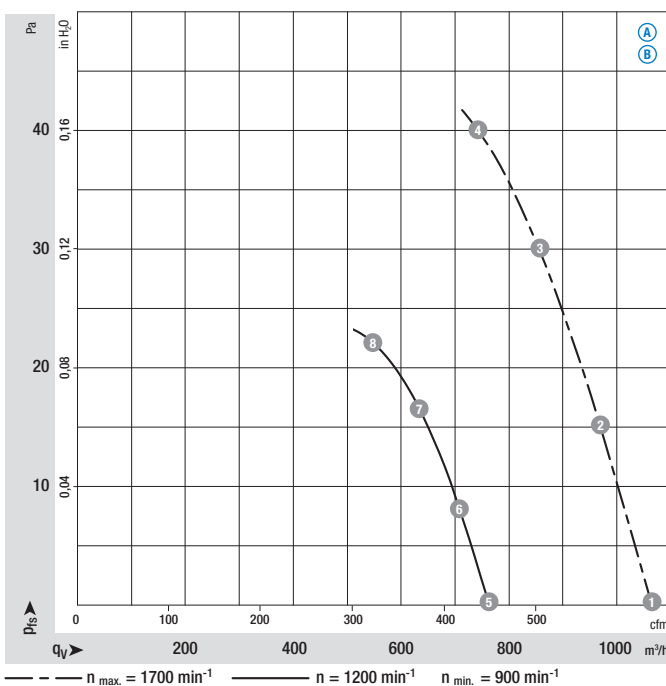

Air performance measured as per: ISO 5801, Installation category A, in ebm-papst full nozzle and with protection against accidental contact

Suction-side noise levels:  $L_{wA}$  as per ISO 13347,  $L_{pA}$  measured at 1 m distance to fan axis

The acoustic values given are only valid under the measurement conditions listed and may vary depending on the installation situation.

With any deviation to the standard setup, the specific values have to be checked and reviewed once installed or fitted!

For detailed information see page 62 ff.

	n rpm	P <sub>e</sub> W	I A	L <sub>wA</sub> dB(A)
Ⓐ 1	1700	30	0,44	62
Ⓐ 2	1700	31	0,45	63
Ⓐ 3	1700	32	0,47	64
Ⓐ 4	1700	32	0,47	65
Ⓐ 5	1200	14	0,22	53
Ⓐ 6	1200	15	0,24	54
Ⓐ 7	1200	16	0,25	55
Ⓐ 8	1200	17	0,26	57
Ⓑ 1	1700	30	0,24	62
Ⓑ 2	1700	31	0,24	63
Ⓑ 3	1700	32	0,24	64
Ⓑ 4	1700	32	0,24	65
Ⓑ 5	1200	14	0,12	53
Ⓑ 6	1200	15	0,13	54
Ⓑ 7	1200	16	0,14	55
Ⓑ 8	1200	17	0,14	57

- Electr. connection:

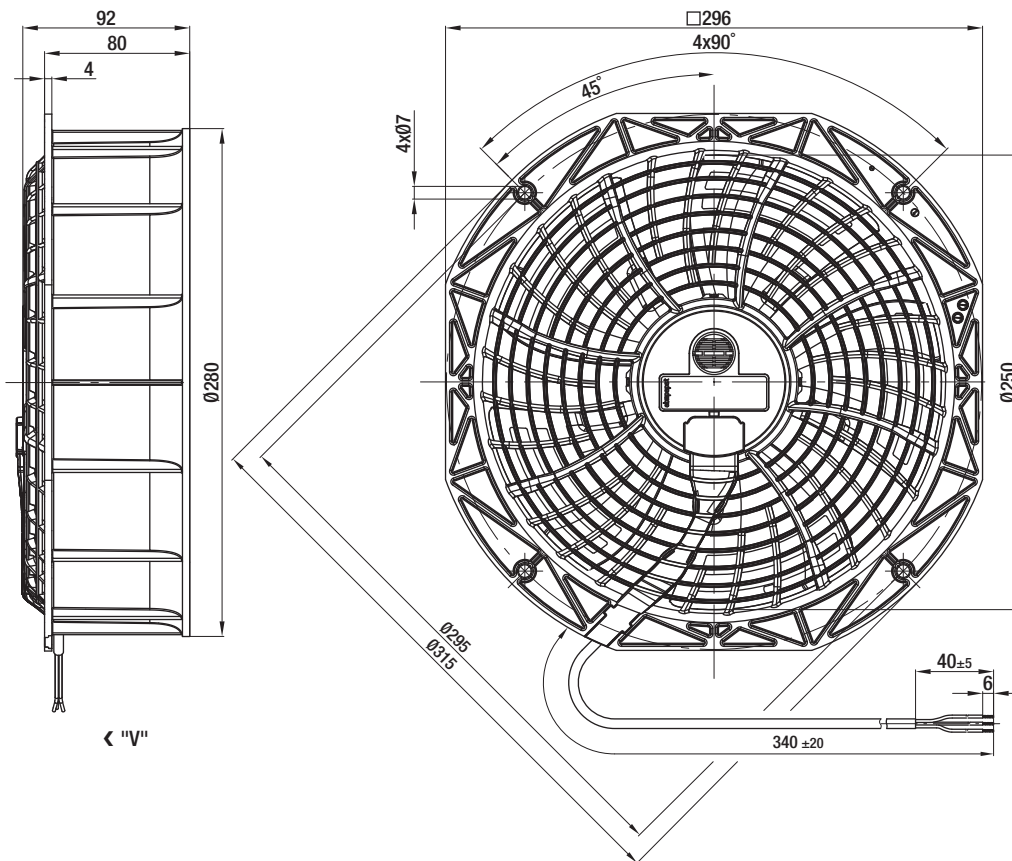
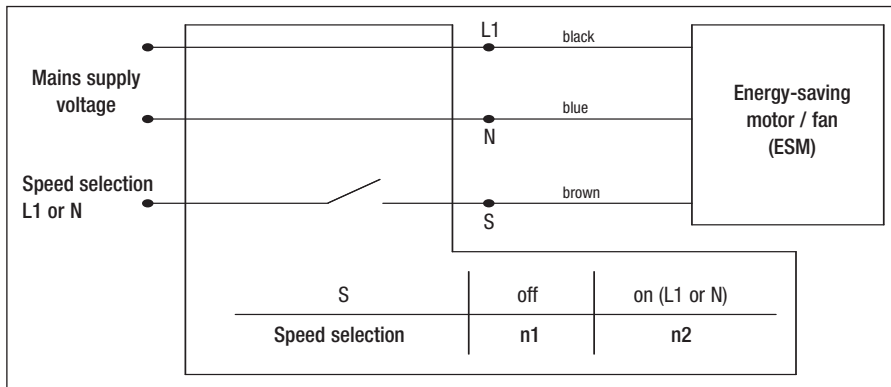

# Energy-saving axial fans

Ø 300



- **Material:** Wall ring: Plastic PP  
Blade: Plastic PA, fiberglass-reinforced
- **Number of blades:** 5
- **Direction of air flow:** "V", exhaust over struts
- **Direction of rotation:** Counter-clockwise, seen on rotor
- **Type of protection:** IP 54
- **Insulation class:** "B"
- **Mounting position:** Any
- **Condensate discharges:** None
- **Mode of operation:** Con. operation (S1)
- **Bearings:** Maintenance-free ball bearings
- **Motor protection:** Via electronics and TOP
- **Electrical connection:** Plug-in connection on motor side
- **Protection class:** II
- **Product conforming to standard:** CE
- **Approvals:** VDE, UL, CSA, GOST
- **Speed:** Using the programming unit, 2 speeds between  $n_{min}$  and  $n_{max}$  can be programmed.

Nominal data		Curve	Nominal voltage	Frequency	Speed/rpm <sup>(1)</sup>	Max. input power <sup>(1)</sup>	Max. current draw <sup>(1)</sup>	Max. back pressure	Perm. amb. temp.	Mass
Type	Motor	VAC	Hz	rpm	W	A	Pa	°C	kg	
<b>W1G300-BB23 -01</b>	M1G 055-BI	Ⓐ 1~115	50/60	1300	35	0,50	35	-30..+50	1,75	
<b>W1G300-BB19 -01</b>	M1G 055-BI	Ⓑ 1~230	50/60	1300	35	0,27	35	-30..+50	1,75	

subject to alterations

<sup>(1)</sup> Nominal data in operating point with maximum load and 115 or 230 VAC

## Curves

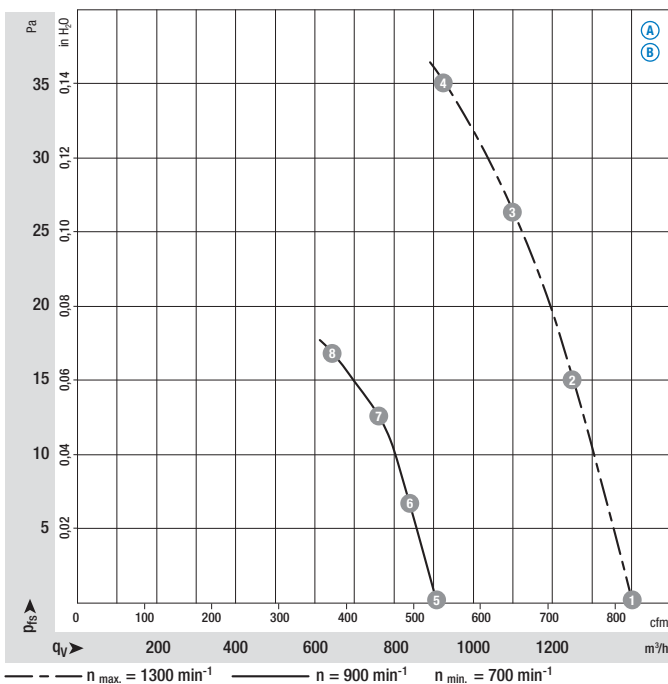

Air performance measured as per: ISO 5801, Installation category A, in ebm-papst full nozzle and with protection against accidental contact

Suction-side noise levels:  $L_{wA}$  as per ISO 13347,  $L_pA$  measured at 1 m distance to fan axis

The acoustic values given are only valid under the measurement conditions listed and may vary depending on the installation situation.

With any deviation to the standard setup, the specific values have to be checked and reviewed once installed or fitted!

For detailed information see page 62 ff.

	n rpm	P <sub>e</sub> W	I A	L <sub>wA</sub> dB(A)
Ⓐ 1	1300	28	0,41	58
Ⓐ 2	1300	31	0,46	58
Ⓐ 3	1300	32	0,47	57
Ⓐ 4	1300	35	0,50	58
Ⓐ 5	900	12	0,24	50
Ⓐ 6	900	14	0,25	49
Ⓐ 7	900	15	0,26	49
Ⓐ 8	900	16	0,27	50
Ⓑ 1	1300	32	0,25	58
Ⓑ 2	1300	34	0,27	58
Ⓑ 3	1300	34	0,27	57
Ⓑ 4	1300	35	0,27	58
Ⓑ 5	900	13	0,12	50
Ⓑ 6	900	14	0,13	49
Ⓑ 7	900	15	0,14	49
Ⓑ 8	900	16	0,15	50

– Electr. connection:

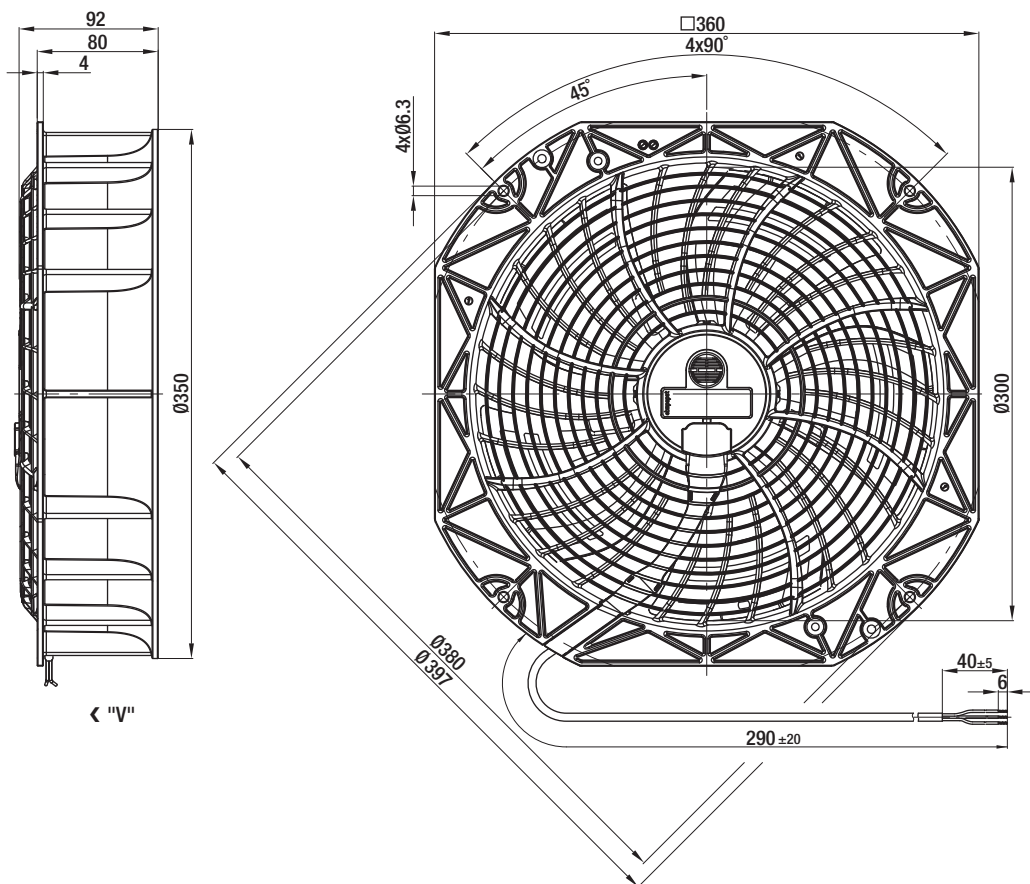
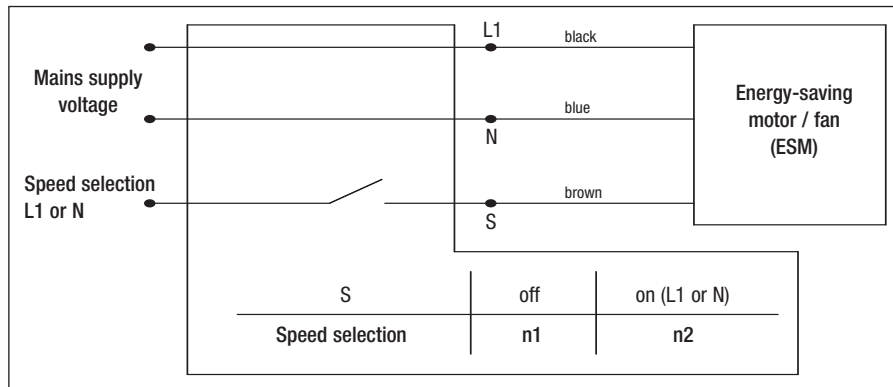

# Energy-saving axial fans

Ø 300

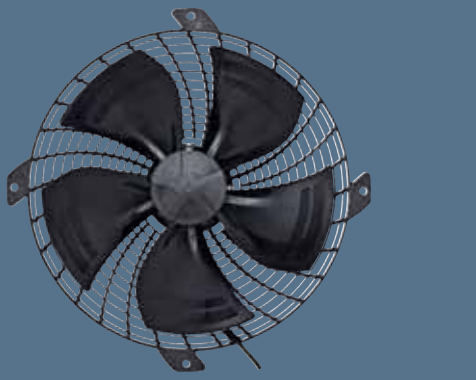

- **Material:** Blade: Plastic PA, fiberglass-reinforced  
Guard grille: epylen
- **Number of blades:** 5
- **Direction of air flow:** "A", intake over guard grille
- **Direction of rotation:** Counter-clockwise, seen on rotor
- **Type of protection:** IP 54
- **Insulation class:** "B"
- **Mounting position:** Any
- **Condensate discharges:** None
- **Mode of operation:** Con. operation (S1)
- **Bearings:** Maintenance-free ball bearings
- **Motor protection:** Via electronics and TOP
- **Electrical connection:** Plug-in connection on motor side
- **Protection class:** II
- **Product conforming to standard:** CE
- **Approvals:** VDE, UL, CSA, GOST
- **Speed:** Using the programming unit, 2 speeds between  $n_{min}$  and  $n_{max}$  can be programmed.

Nominal data		Curve	Nominal voltage	Frequency	Speed/rpm <sup>(1)</sup>	Max. input power <sup>(1)</sup>	Max. current draw <sup>(1)</sup>	Max. back pressure	Perm. amb. temp.	Mass
Type	Motor	VAC	Hz	rpm	W	A	Pa	°C	kg	
<b>S1G 300-CA23 -02</b>	M1G 055-BI	Ⓐ	1~ 115	50/60	1250	35	0,56	35	-30..+50	1,4
<b>S1G 300-CA19 -02</b>	M1G 055-BI	Ⓑ	1~ 230	50/60	1250	35	0,27	35	-30..+50	1,4

subject to alterations

<sup>(1)</sup> Nominal data in operating point with maximum load and 115 or 230 VAC

## Curves

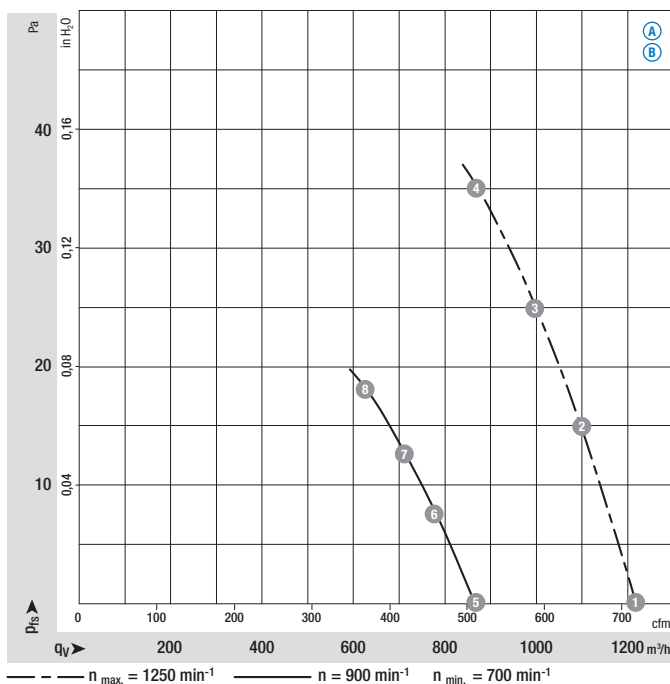

Air performance measured as per: ISO 5801, Installation category A, in ebm-papst short nozzle and with protection against accidental contact

Suction-side noise levels:  $L_{wA}$  as per ISO 13347,  $L_{pA}$  measured at 1 m distance to fan axis

The acoustic values given are only valid under the measurement conditions listed and may vary depending on the installation situation.

With any deviation to the standard setup, the specific values have to be checked and reviewed once installed or fitted!

For detailed information see page 62 ff.

	n rpm	P <sub>e</sub> W	I A	L <sub>wA</sub> dB(A)
Ⓐ 1	1250	31	0,45	64
Ⓐ 2	1250	32	0,47	62
Ⓐ 3	1250	32	0,48	62
Ⓐ 4	1250	35	0,56	63
Ⓐ 5	900	13	0,24	55
Ⓐ 6	900	14	0,26	54
Ⓐ 7	900	16	0,30	53
Ⓐ 8	900	17	0,32	54
Ⓑ 1	1250	27	0,21	64
Ⓑ 2	1250	30	0,23	62
Ⓑ 3	1250	32	0,24	62
Ⓑ 4	1250	35	0,27	63
Ⓑ 5	900	13	0,12	55
Ⓑ 6	900	14	0,13	54
Ⓑ 7	900	16	0,15	53
Ⓑ 8	900	17	0,16	54

– Electr. connection:

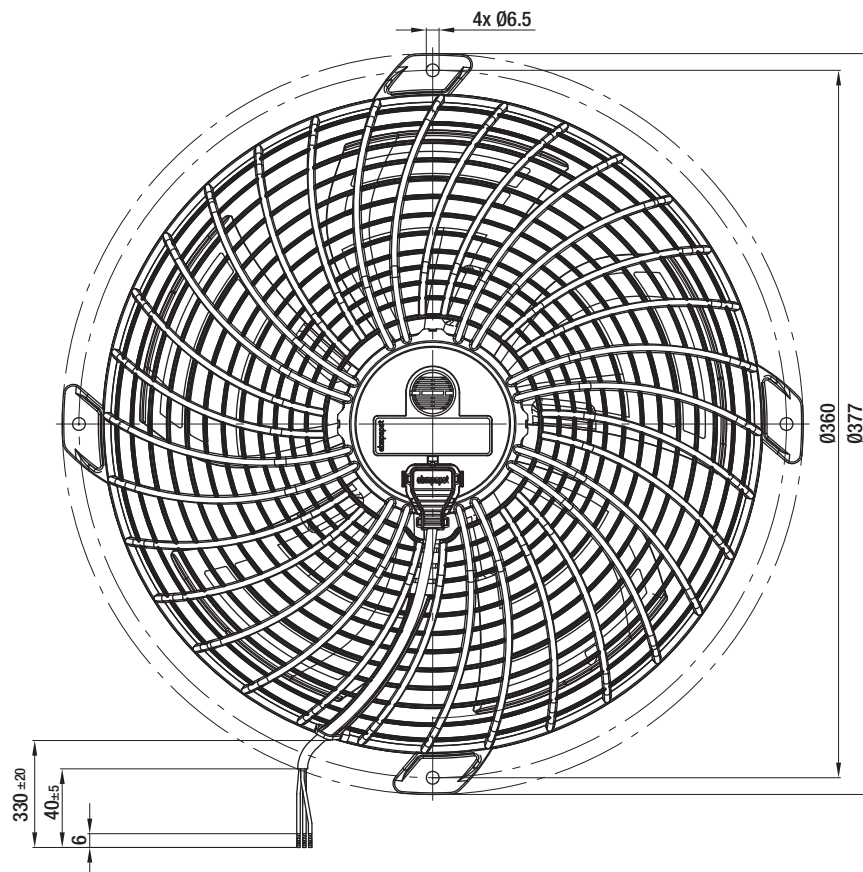
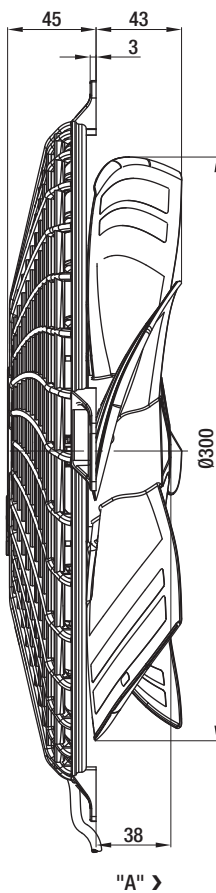
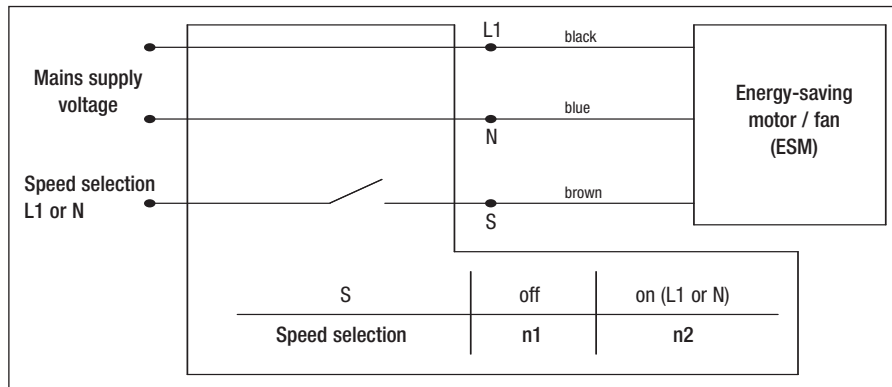

Connection lead (total length 450 mm) is fitted ex works and can be detached  
Other lengths available as accessory.

### **The perfect combination!**

For the new energy saving centrifugal modules, we have combined a backward curved centrifugal impeller already established on the market with new compact modules. The result is a highly compact unit with an integrated inlet nozzle and motor suspension directly connected to the mounting plate. The mounting plate, inlet nozzle and motor suspension consist of a robust and durable plastic. This has the advantage that no compromises have to be made in the aero-acoustic design.

The energy saving centrifugal modules are available with impellers with a 190 and 220 mm diameter. They are extremely compact and easy to install. Intricate adjustments to the impeller for the nozzle are not necessary. An inlet side guard grille is available for installation as an accessory.

The new diagonal K1G200 with an energy saving motor rounds out the series. The diagonal impeller design particularly distinguishes itself through its noise-optimised and air flow-optimised performance in the medium pressure range and sets new benchmarks in the process.

### **Take advantage of the benefits offered by a completely pre-installed functional unit:**

- Compact design
- Optimised, tested and guaranteed functional unit
- Plug-and-play characteristic
- Easy installation
- Energy saving motor (ESM)
- Optional guard grille
- Simple logistics

### **Maximum efficiency**

The energy saving motors achieve a maximum efficiency of over 70%. So they only need 1/3 to 1/6 the power of an otherwise normal shaded-pole motor. But higher efficiency also means lower intrinsic heating during operation at the same time, which dissipates less heat into the surrounding area. This means that less cooling power must be generated from the outset, thus resulting in additional energy savings.



# The new energy-saving centrifugal modules

Size 190, backward curved	34
Size 220, backward curved	36
Size 200, diagonal	38



# EC centrifugal module

backward curved, Ø 190

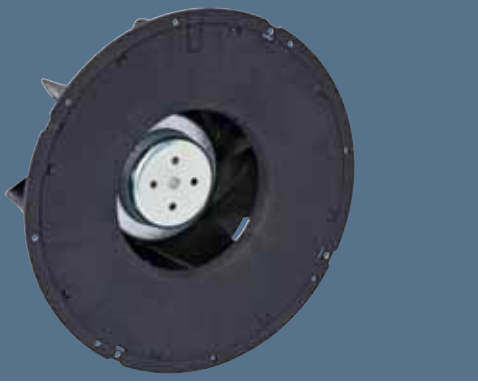

- **Material:** Housing: Plastic PA, fiberglass-reinforced  
Impeller: Plastic PA, fiberglass-reinforced  
Rotor: Galvanised
- **Number of blades:** 7
- **Direction of rotation:** clockwise, seen on rotor
- **Type of protection:** IP 54
- **Insulation class:** "B"
- **Mounting position:** Any
- **Condensate discharges:** None, open rotor
- **Mode of operation:** Con. operation (S1)
- **Bearings:** Maintenance-free ball bearings
- **Motor protection:** Via electronics and TOP
- **Electrical connection:** Plug-in connection on motor side
- **Protection class:** II
- **Product conforming to standard:** CE
- **Approvals:** VDE, UL, CSA, GOST are applied for
- **Speed:** Using the programming unit, 2 speeds between  $n_{min}$  and  $n_{max}$  can be programmed.

Nominal data		Curve	Nominal voltage	Frequency	Speed/rpm <sup>(1)</sup>	Max. input power <sup>(1)</sup>	Max. current draw <sup>(1)</sup>	Perm. amb. temp.
Type	Motor	VAC	Hz	rpm	W	A	°C	
<b>K1G 190</b>	M1G 055-BD	Ⓐ	1~ 115	50/60	2000	30	0,45	-30..+50
<b>K1G 190</b>	M1G 055-BD	Ⓑ	1~ 230	50/60	2000	30	0,24	-30..+50

subject to alterations

(1) Nominal data in operating point with maximum load and 115 or 230 VAC

## Curves

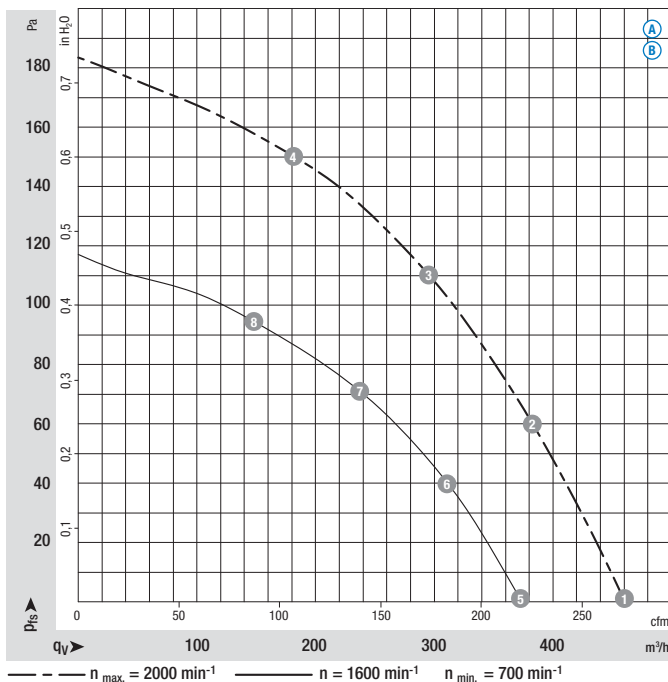

Air performance measured as per: ISO 5801, Installation category A, without protection against accidental contact

Suction-side noise levels:  $L_{WA}$  as per ISO 13347,  $L_{pA}$  measured at 1 m distance to fan axis

The acoustic values given are only valid under the measurement conditions listed and may vary depending on the installation situation.

With any deviation to the standard setup, the specific values have to be checked and reviewed once installed or fitted!

For detailed information see page 62 ff.

	n rpm	P <sub>e</sub> W	I A	L <sub>WA</sub> dB(A)
Ⓐ 1	2000	21	0,34	62
Ⓐ 2	2000	25	0,38	60
Ⓐ 3	2000	30	0,45	59
Ⓐ 4	2000	26	0,39	60
Ⓐ 5	1600	13	0,19	57
Ⓐ 6	1600	15	0,25	55
Ⓐ 7	1600	17	0,27	53
Ⓐ 8	1600	15	0,26	55
Ⓑ 1	2000	21	0,16	62
Ⓑ 2	2000	25	0,19	60
Ⓑ 3	2000	30	0,24	59
Ⓑ 4	2000	26	0,20	60
Ⓑ 5	1600	13	0,10	57
Ⓑ 6	1600	15	0,11	55
Ⓑ 7	1600	17	0,13	53
Ⓑ 8	1600	15	0,12	55

– Electr. connection:

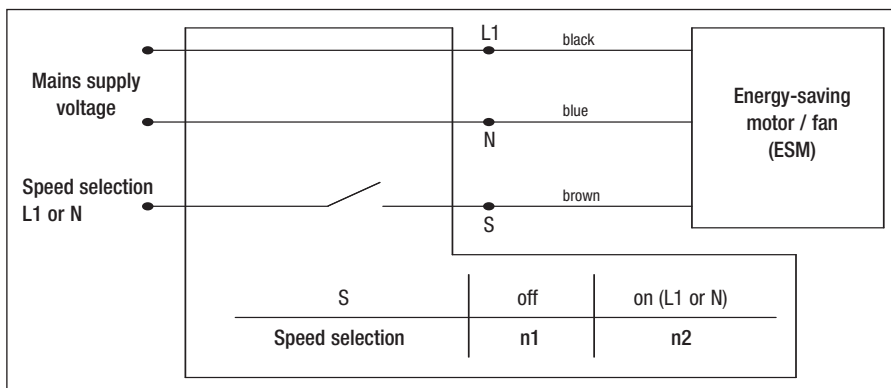

Mass of centrifugal module with support bracket

Centrifugal module with support bracket	kg
K1G 190-AD50 -02	1,3
K1G 190-AD73 -02	1,3

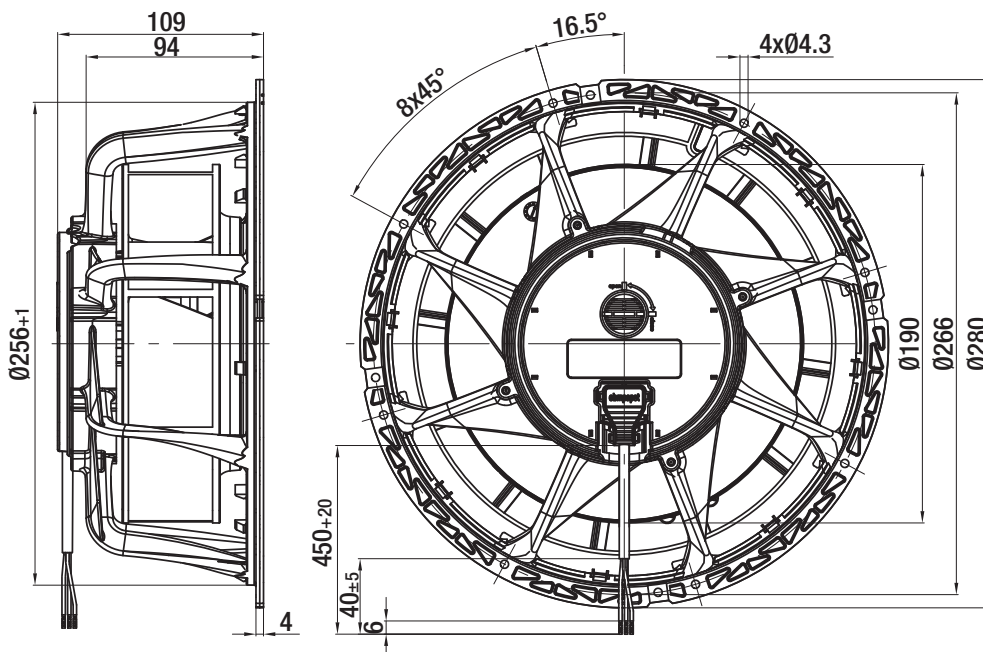

Connection lead (total length 450 mm) is fitted ex works and can be detached  
Other lengths available as accessory.

# EC centrifugal module

backward curved, Ø 220

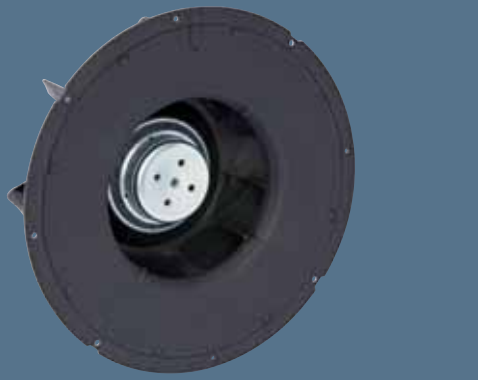

- **Material:** Housing: Plastic PA, fibreglass-reinforced  
Impeller: Plastic PA, fibreglass-reinforced  
Rotor: Galvanised
- **Number of blades:** 11
- **Direction of rotation:** clockwise, seen on rotor
- **Type of protection:** IP 54
- **Insulation class:** "B"
- **Mounting position:** Any
- **Condensate discharges:** None, open rotor
- **Mode of operation:** Con. operation (S1)
- **Bearings:** Maintenance-free ball bearings
- **Motor protection:** Via electronics and TOP
- **Electrical connection:** Plug-in connection on motor side
- **Protection class:** II
- **Product conforming to standard:** CE
- **Approvals:** VDE, UL, CSA, GOST are applied for
- **Speed:** Using the programming unit, 2 speeds between  $n_{min}$  and  $n_{max}$  can be programmed.

Nominal data		Curve	Nominal voltage	Frequency	Speed/rpm <sup>(1)</sup>	Max. input power <sup>(1)</sup>	Max. current draw <sup>(1)</sup>	Perm. amb. temp.
Type	Motor	VAC	Hz	rpm	W	A	°C	
K1G 220	M1G 055-BD	Ⓐ 1~ 115	50/60	1600	32	0,50	-30..+50	
K1G 220	M1G 055-BD	Ⓑ 1~ 230	50/60	1600	33	0,25	-30..+50	

subject to alterations

(1) Nominal data in operating point with maximum load and 115 or 230 VAC

## Curves

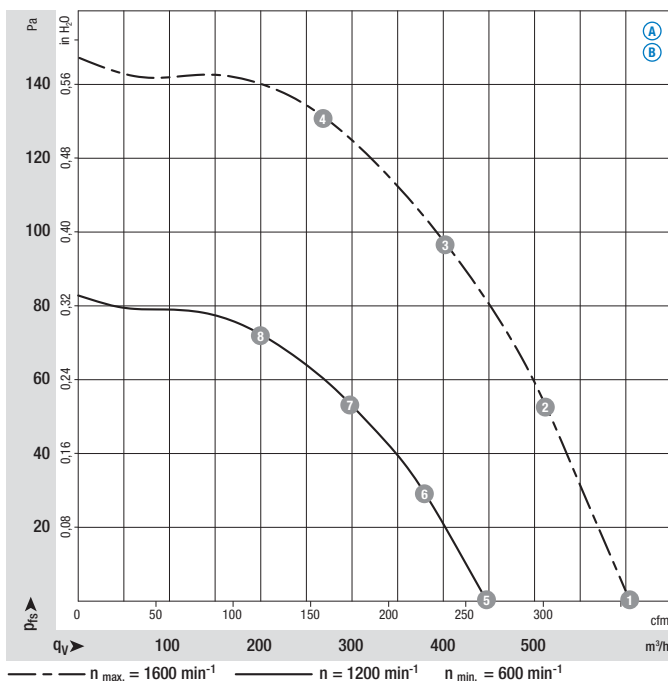

Air performance measured as per: ISO 5801, Installation category A, without protection against accidental contact

Suction-side noise levels:  $L_{WA}$  as per ISO 13347,  $L_pA$  measured at 1 m distance to fan axis

The acoustic values given are only valid under the measurement conditions listed and may vary depending on the installation situation.

With any deviation to the standard setup, the specific values have to be checked and reviewed once installed or fitted!

For detailed information see page 62 ff.

	n rpm	$P_e$ W	I A	$L_{WA}$ dB(A)
Ⓐ 1	1600	18	0,25	59
Ⓐ 2	1600	26	0,37	57
Ⓐ 3	1600	32	0,50	55
Ⓐ 4	1600	30	0,44	56
Ⓐ 5	1200	7	0,10	52
Ⓐ 6	1200	11	0,15	50
Ⓐ 7	1200	13	0,18	48
Ⓐ 8	1200	12	0,18	50
Ⓑ 1	1600	18	0,14	59
Ⓑ 2	1600	25	0,21	57
Ⓑ 3	1600	33	0,25	55
Ⓑ 4	1600	30	0,25	56
Ⓑ 5	1200	7	0,06	52
Ⓑ 6	1200	10	0,08	50
Ⓑ 7	1200	13	0,11	48
Ⓑ 8	1200	12	0,10	50

– Electr. connection:

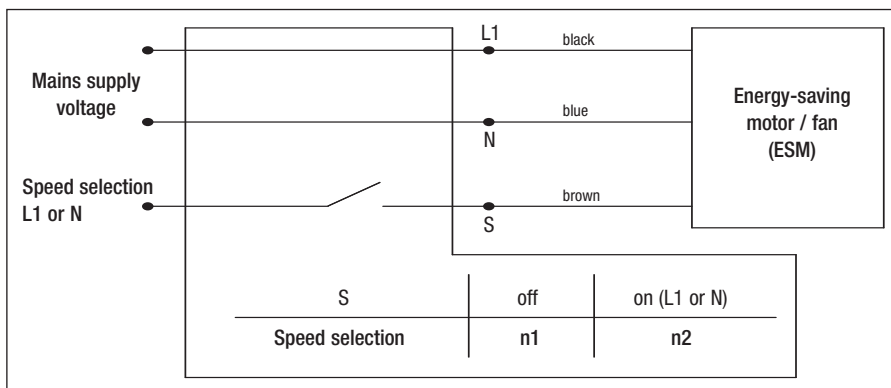

Mass of centrifugal module with support bracket

Centrifugal module with support bracket	kg
K1G 220-AF90 -02	1,4
K1G 220-AF92 -02	1,4

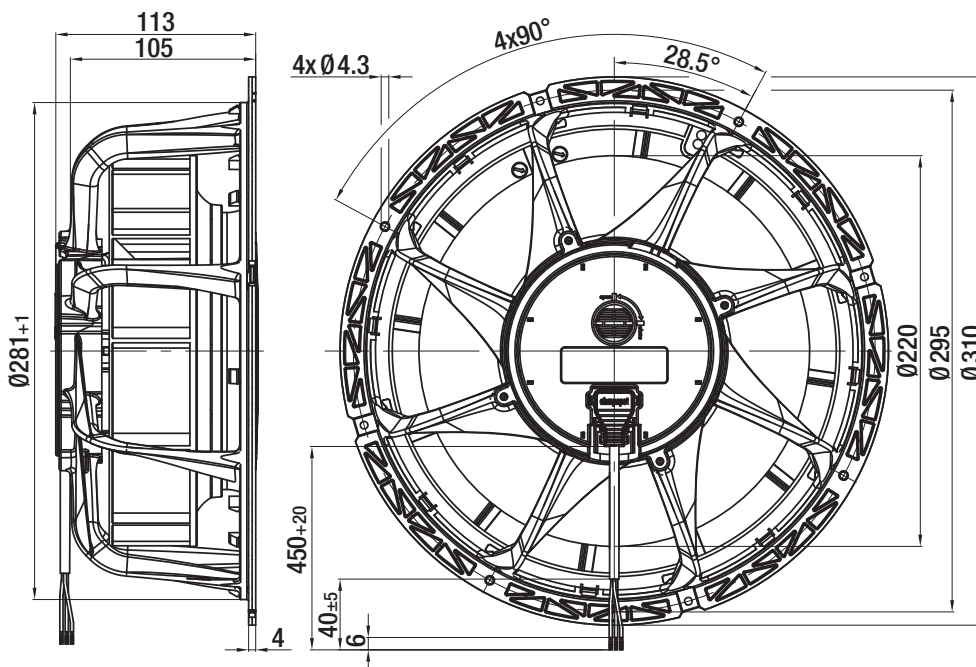

Connection lead (total length 450 mm) is fitted ex works and can be detached  
Other lengths available as accessory.

# EC centrifugal module

diagonal, Ø 200



- **Material:** Housing: Plastic PA, fibreglass-reinforced  
Blades: Plastic PA, fibreglass-reinforced
- **Number of blades:** 7
- **Direction of rotation:** clockwise, seen on rotor
- **Type of protection:** IP 54
- **Insulation class:** "B"
- **Mounting position:** Any
- **Condensate discharges:** None, open rotor
- **Mode of operation:** Con. operation (S1)
- **Bearings:** Maintenance-free ball bearings
- **Motor protection:** Via electronics and TOP
- **Electrical connection:** Plug-in connection on motor side
- **Protection class:** II
- **Product conforming to standard:** CE
- **Approvals:** VDE, UL, CSA, GOST are applied for
- **Speed:** Using the programming unit, 2 speeds between  $n_{min}$  and  $n_{max}$  can be programmed.

Nominal data		Curve	Nominal voltage	Frequency	Speed/rpm <sup>(1)</sup>	Max. input power <sup>(1)</sup>	Max. current draw <sup>(1)</sup>	Max. back pressure	Perm. amb. temp.
Type	Motor	VAC	Hz	rpm	W	A	PA	°C	
<b>K1G 200</b>	M1G 055-BD	Ⓐ 1~ 115	50/60	2000	31	0,50	120	-30..+50	
<b>K1G 200</b>	M1G 055-BD	Ⓑ 1~ 230	50/60	2000	35	0,30	120	-30..+50	

subject to alterations

(1) Nominal data in operating point with maximum load and 115 or 230 VAC

## Curves

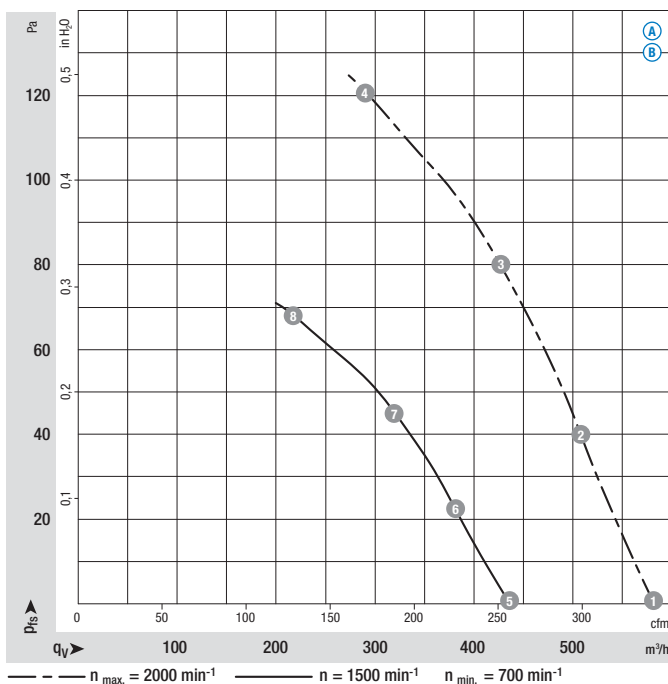

Air performance measured as per: ISO 5801, Installation category A, without protection against accidental contact

Suction-side noise levels:  $L_{wA}$  as per ISO 13347,  $L_{pA}$  measured at 1 m distance to fan axis

The acoustic values given are only valid under the measurement conditions listed and may vary depending on the installation situation.

With any deviation to the standard setup, the specific values have to be checked and reviewed once installed or fitted!

For detailed information see page 62 ff.

	n rpm	P <sub>e</sub> W	I A	L <sub>wA</sub> dB(A)
Ⓐ 1	2000	27	0,38	63
Ⓐ 2	2000	29	0,42	62
Ⓐ 3	2000	31	0,50	62
Ⓐ 4	2000	30	0,43	62
Ⓐ 5	1500	14	0,22	57
Ⓐ 6	1500	16	0,24	56
Ⓐ 7	1500	17	0,26	55
Ⓐ 8	1500	16	0,25	55
Ⓑ 1	2000	31	0,24	63
Ⓑ 2	2000	33	0,26	62
Ⓑ 3	2000	35	0,30	62
Ⓑ 4	2000	35	0,27	62
Ⓑ 5	1500	16	0,13	57
Ⓑ 6	1500	19	0,14	56
Ⓑ 7	1500	20	0,18	55
Ⓑ 8	1500	18	0,14	55

– Electr. connection:

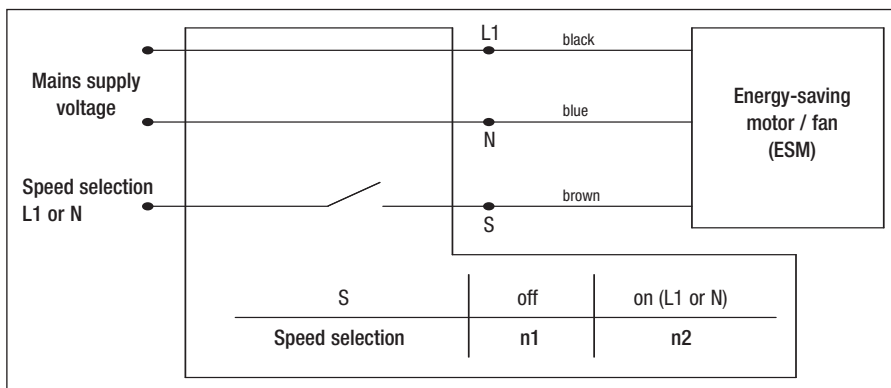

Mass of centrifugal module with support bracket

Centrifugal module with support bracket

kg

K1G 200-AA95 -02

1,2

K1G 200-AA73 -02

1,2

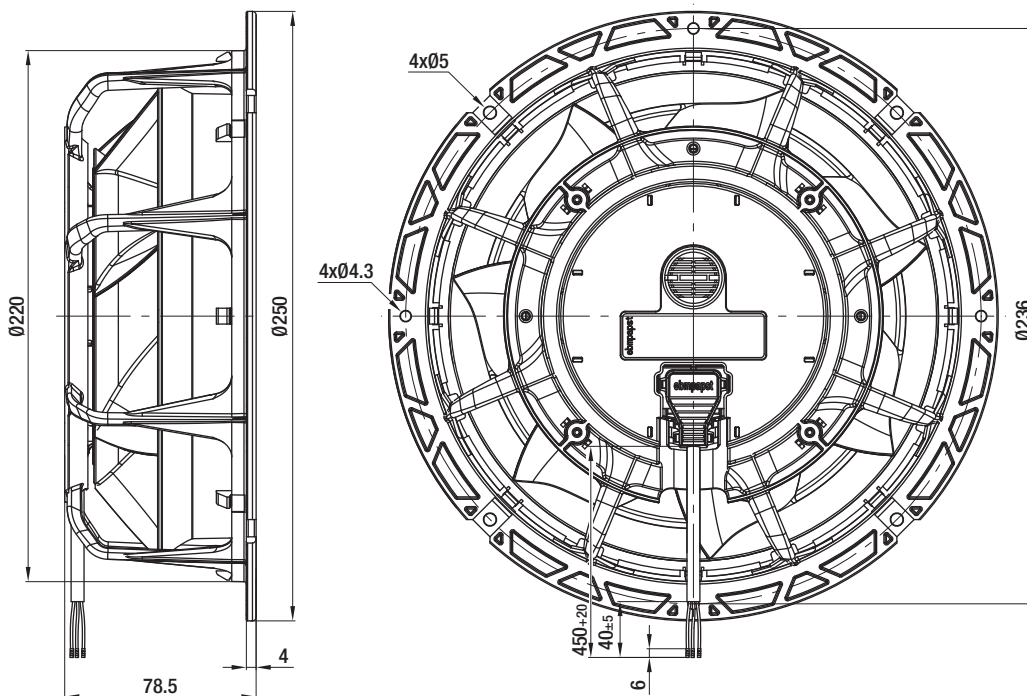

Connection lead (total length 450 mm) is fitted ex works and can be detached. Other lengths available as accessory.

# Connection leads (ESM)

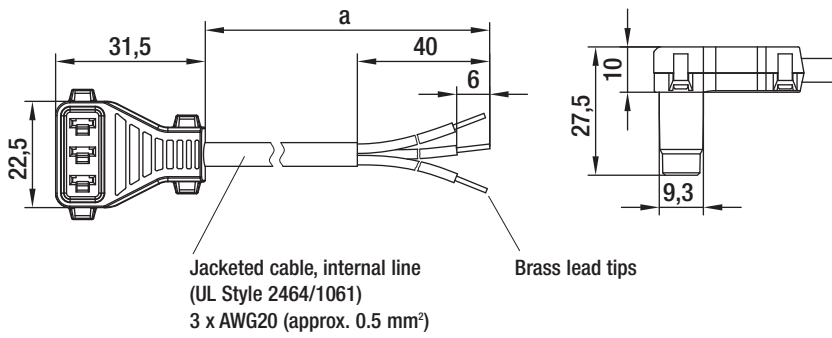

- **Design:** Cable conforms to UL standards, sealed plug. Custom-built connection leads on request.

## Connection lines for energy-saving motors 115/230 VAC

Part no.	a
10637-4-1040	450
10640-4-1040	600
10638-4-1040	1500
10639-4-1040	2000

subject to alterations

# Guard grilles (ESM)

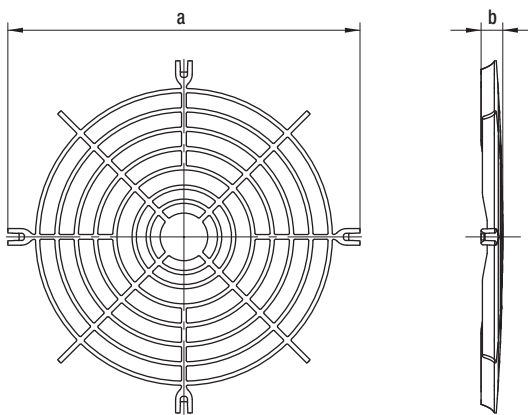

- **Material:** Plastic PA, fibreglass-reinforced

## Guard grille (sucking side) for energy-saving centrifugal modules

Part no.	Size	a	b
19051-2-2929	190	133,0	9,0
22051-2-2929	220	166,0	8,7

subject to alterations



# Connection leads (ESM)

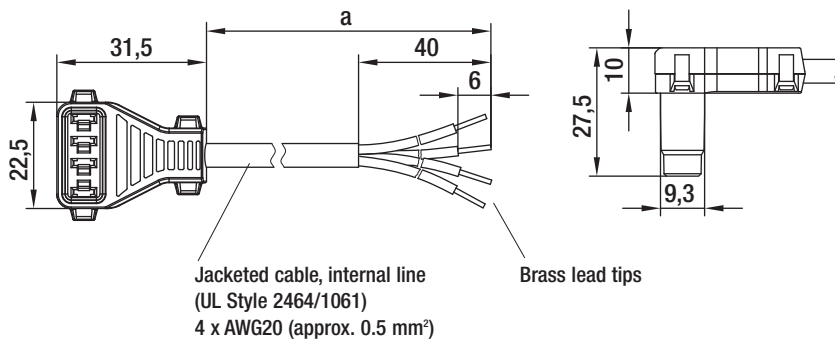

- **Design:** Cable conforms to UL standards, sealed plug. Custom-built connection leads on request.

## Connection lines for energy-saving motors 24 VDC

Part no.	a
10710-4-1040	450
10711-4-1040	1500

subject to alterations

# Handheld Programmer



- Easy speed programming
- Battery operated
- User-friendly navigation menu
- Protective boot with kickstand

## For Energy Saving Motor (ESM) based products

Part no.

CBC 000-AF08-01

subject to alterations

Makes quick work of programming the two ESM selectable operating speeds. Eliminates the need for a personal computer, software, power adapter and 2nd cable. Good for production line or field service use. Automatic shut-off function for an extended battery life. Mini-USB connector for uploading software upgrades. Batteries, programming cable and operating manual included.

# Pressure sensor

for pressure-controlled speed control



- **Material:** Housing made of PA  
Pressure connection made of brass
- **Type of protection:** IP 65 according to EN 60529 / IEC 529
- **Suitable for commonly used refrigerants**  
(A R134A; B R407C, R404A, R507)
- **Easy installation via pressure connection with 7/16"-20 UNF female thread with Schrader valve opener**
- **Power supply via 10 VDC**
- **0-10 VDC control output signal for pressure-dependent speed control of the fan**
- **Delivered in individual packaging**

Nominal data		Nominal voltage	Max. power input	Setting range cut-off	Factory setting cut-off	Test pressure	Max. operating pressure	Max. medium temperature	Perm. amb. temp.	Mass
Part no.		VDC	mA	bar	bar	bar	bar	°C	°C	g
40100-4-7380	(A)	10	1	4 to 12.5	7.8	30	27	70	-20 to +65	125
40101-4-7380	(B)	10	1	10 to 21	15.5	36	32	70	-20 to +65	125

subject to alterations

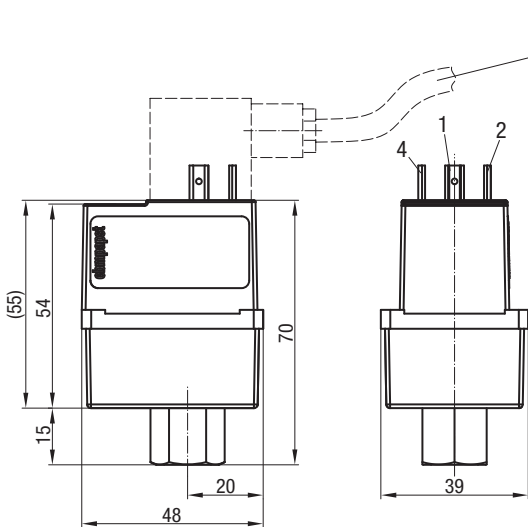

Connecting cable with plug (1.5 m)  
not included in scope of delivery.  
Part No.: 24010-4-1040

- 1 = Signal 0-10 V
- 2 = 10 V
- 4 = GND

### Electr. connection:

Pressure sensor

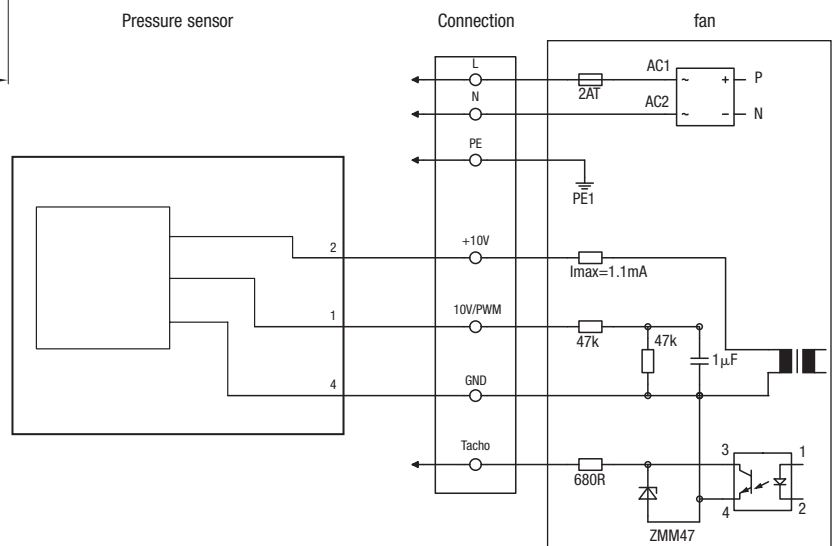
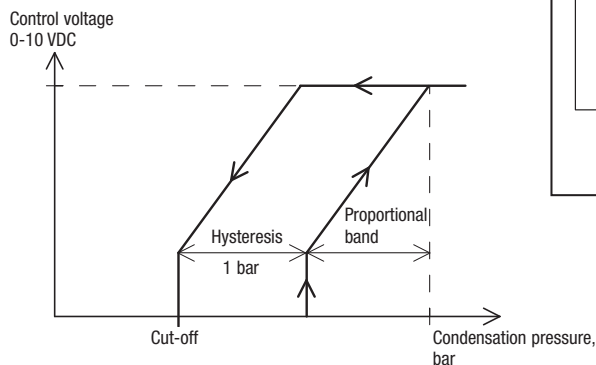

# Connection lead (Pressure sensor)

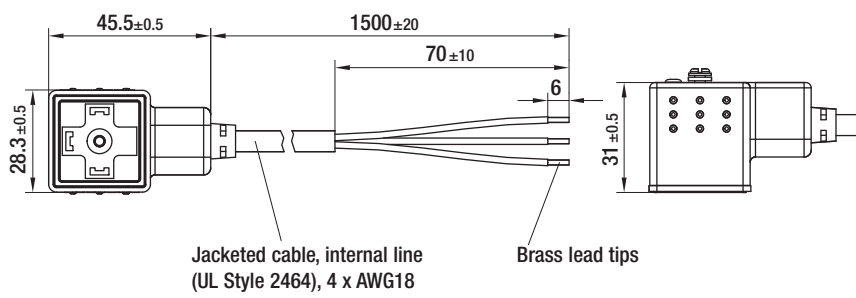

– Design: Single packed in plastic bag.

## Connection line for pressure sensor

Part no.	a
24010-4-1040	1500

subject to alterations

# Guard grilles (ACi)

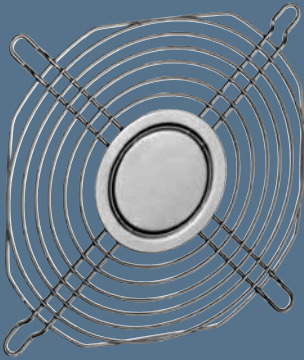

- Guard grille acc. to DIN EN ISO 13857 (previously EN 294), made of galvanised or nickel-plated and passivated steel wire for device fans.
- Additional guard grilles that do not conform to DIN EN ISO 13857 are available on request.
- Our guard grilles are specially designed for use with ebm-papst fans. Their design ensures maximum safety with minimum effect on the operating noise level. Note that when using guard grilles from other manufacturers, compliance with safety-related distances will not always be present.

Fan series	Guard grilles	
ACi 4400	LZ30	Intake side
ACi 4400	LZ30	Outlet side

LZ30 Fan size 119 x 119

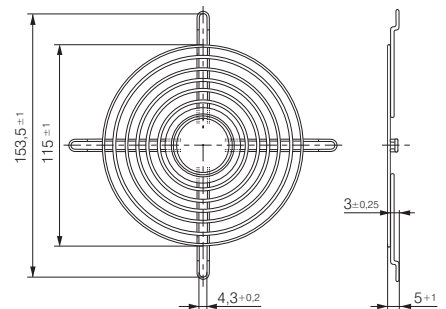

# Connector cables (ACi)

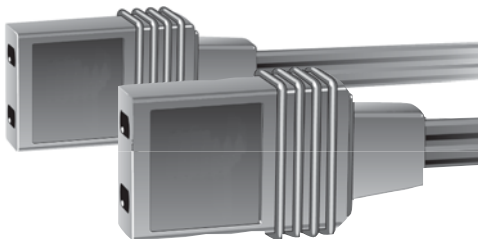

- Connector cable with injection-moulded plug in various lengths.
- Strand ends with core-crimping sleeve, core-end sleeve or tin-plated.

Plug model	L1 (mm)	Leads	Plug	Leads end	Lead colour	Receptacle for tabs	Application
LZ120	610	0,5 mm <sup>2</sup>	straight	C	black/black	2,8 x 0,5	AC
LZ120-4	2 000	0,5 mm <sup>2</sup>	straight	A	black/black	2,8 x 0,5	AC
LZ120-16	800	0,5 mm <sup>2</sup>	straight	B	black/black	2,8 x 0,5	AC
LZ120-18	4 000	0,5 mm <sup>2</sup>	straight	A	black/black	2,8 x 0,5	AC
LZ126	1 000	0,5 mm <sup>2</sup>	straight	C	black/black	2,8 x 0,5	AC
LZ127	1 600	0,5 mm <sup>2</sup>	straight	B	black/black	2,8 x 0,5	AC
LZ130-1	610	0,82 mm <sup>2</sup>	straight	C	black/black	2,8 x 0,5	AC

Core crimp sleeve

Leads end A

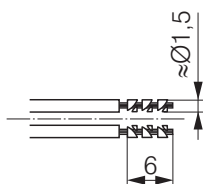

Tin-plated

Leads end B

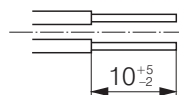

Core end sleeve

Leads end C

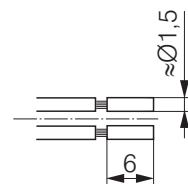

## Fan filter guard drilles (ACi)



- Filter guard grille consisting of 3 parts: outer grille barrier, inner fastening plate and replaceable filter mat.
- Grille barrier made of moulded polycarbonate (PC), with matted surface.
- Fast and easy exchange of filter mat via a quick release on the grille barrier.
- Fastening plate made of wire netting, with black powder coating.
- Filter mat can be replaced while the fan is running, protection provided by welded wire netting.
- Filter mat made of white, synthetically bonded fibres.

Protection filter	Fan size	A	B	C	D	Replacement filter*
FF119	119 x 119 mm	162	136	18,5	104,5	RF 119

\* Replacement filters only in packs of 5.

### FF 119

Fan size: 119 x 119 mm

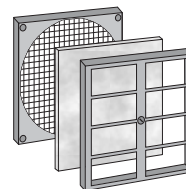

#### Filter capacity

A fan filter guard filters out up to 75% of dust particles up to a size of 5-10 microns and withstands temperatures of up to 100°C. Flame retardant in accordance with DIN 53438, grade F1. For installed, clean filters, an air flow reduction of 20 – 30% can be assumed.

# Electrical connections

## W1G 200 - EF41 - 01 / W1G 200 - EF01 - 01

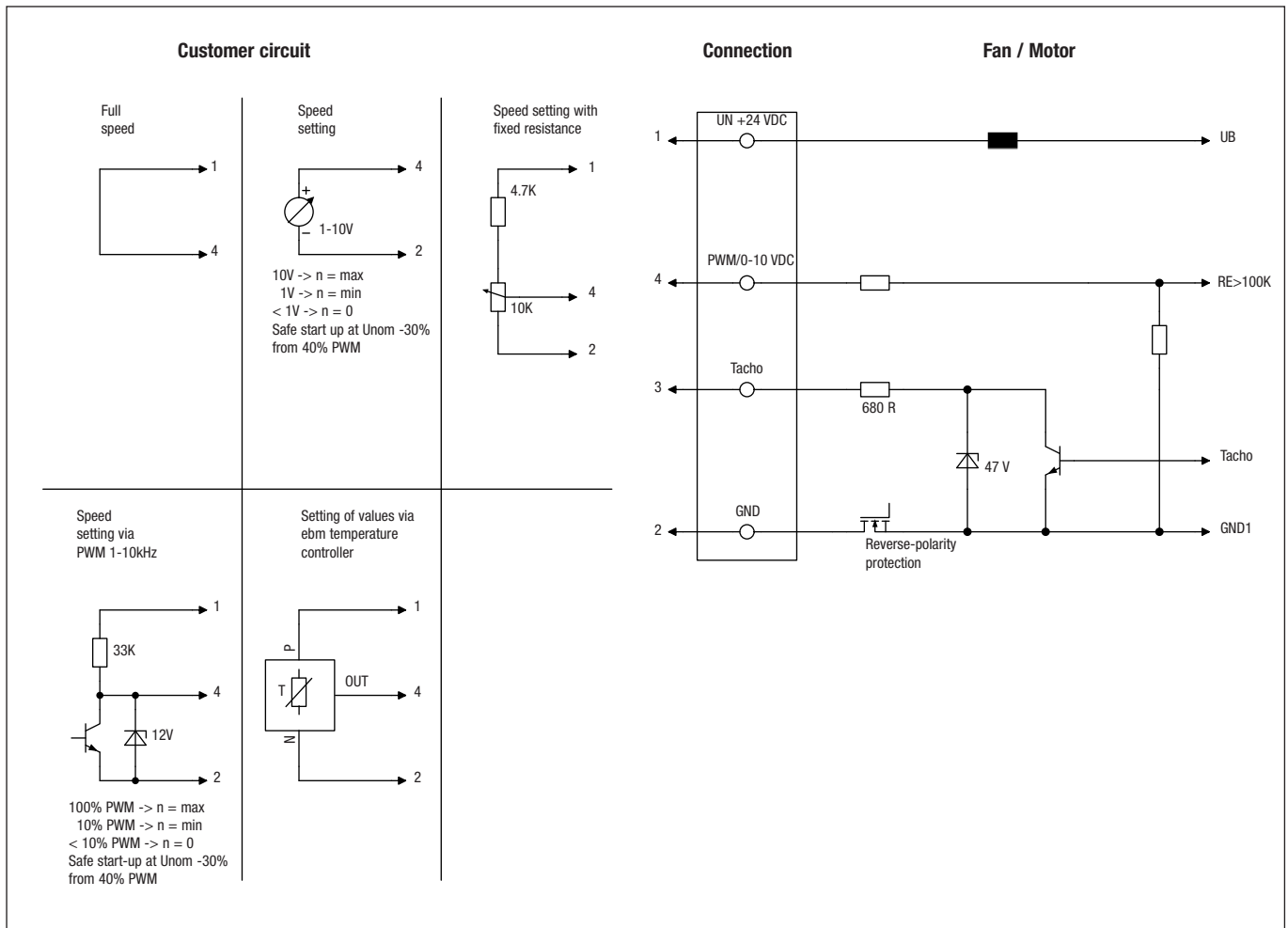

Line	No.	Connection	Colour	Assignment / function
1	1	Un +24 VDC	red	Power supply 24 VDC, residual ripple 3.5 %, see type plate for voltage range
1	2	GND	blue	Reference ground
1	3	Tacho	white	Tacho output: Open Collector, 1 pulse per revolution, Isink max = 10 mA
1	4	PWM / 0-10 VDC	yellow	Control input PWM or 0-10 V, RE > 100K

# Electrical connections

W1G 200 - EC87 - A2 / W1G 200 - EC91 - A4

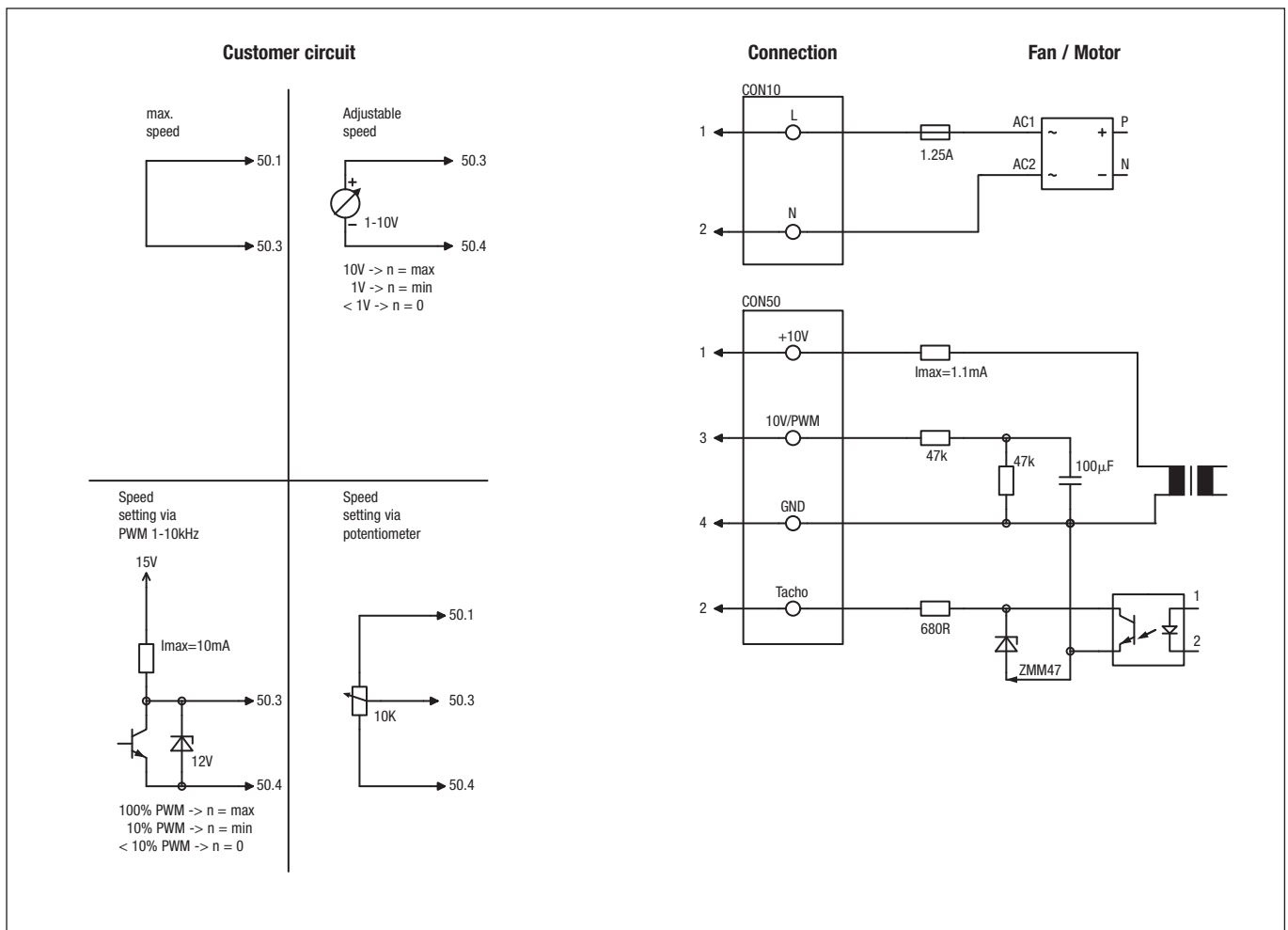

Line	No.	Connection	Colour	Assignment / function
CON10	1	L	black	Power supply 230 VAC, 50 - 60 Hz, see type plate for voltage range
CON10	2	N	blue	Neutral conductor
CON50	1	10V/max.1.1mA	red	Voltage output 10V / 1.1mA, electrically isolated
CON50	2	Tacho	white	Tacho output: Open Collector, 1 pulse per revolution, electrically isolated
CON50	3	0-10V PWM	yellow	Control input 0 - 10 V or PWM, electrically isolated
CON50	4	GND	blue	GND - Connection for control interface

# The smart way to save energy

Classic shaded-pole motors (Q motors) have reached the end of their usefulness. The new iQ motors are just as compact, but they are significantly more intelligent, energy-saving and environmentally friendly. Thanks to ebm-papst GreenTech EC technology, the efficiency has been increased by some 70 %. This means that the switch pays off extremely quickly. And that's not all: With the additional functions of the latest iQ<sup>2</sup> generation, you can increase the efficiency even more with intelligent control options.

## **Exchange your old motor for 70 % more efficiency**

From the outside, the iQ and iQ<sup>2</sup> motors are barely distinguishable from conventional shaded-pole motors. Thus the identical dimensions enable easy replacement without structural modifications or other obstacles. Axial impellers with diameters from 154 to 300 mm can be installed on the iQ motor as usual. The same applies to the mounting flange, the wall ring and the guard grille. Thus the efficiency of many applications can be increased drastically without any development effort.

## **One design – thousands of applications**

Just one design is compatible with the entire range of impellers, from 154 to 300 mm. This makes logistics easier and keeps your development effort low. Moreover, the smallest size, the iQ 3608, is the most compact version of an EC motor in the area of refrigeration technology. With an axial installation depth of only 74 mm, it guarantees the bit of air that is so badly needed in tight spaces.

## **Energy-saving and quiet – throughout its long service**

What all variants have in common is their low-noise performance and very long service life. A critical role is played by a particularly low-friction bearing system with ball bearings. This enables the iQ motors to continue to deliver their enormous savings potential for a very long time.

## **All advantages at a glance**

- High efficiency of up to 70 %
- Constant speed, even in the event of voltage fluctuations
- High running smoothness due to low-friction bearing system
- Intelligent electronics with n-control, overload and locked-rotor protection
- Conventional AC technology can be replaced easily
- Identical accessories and dimensions to Q motor
- Long service life due to maintenance-free ball bearings
- One solution replaces multiple sizes of comparable AC motors
- Available in 24 V, 115 V and 230 V





# The new generation of iQ motors

Quadratic. Practical. Intelligent.

■	Savings potential	51
■	Technical data	52
■	Air performance curves	56



# The smart square: The new additional functions of the iQ<sup>2</sup>

The new iQ<sup>2</sup> motors can do everything the “normal” iQ motors can do – and more, which makes applications such as those in refrigeration technology more efficient. Additional functions enable different operating modes, like one that is customised to your needs or automated reverse operation. Simply select the motor variant that best suits your application.

## iQ<sup>2</sup>



### iQ<sup>2</sup> safety class II.

The iQ<sup>2</sup> safety class II features a special design with plastic housing parts. This makes extra steps such as installing the protective earth conductor (protection class II) unnecessary – and saves you a lot of money.

### iQ<sup>2</sup> reverse on start.

The iQ<sup>2</sup> reverse on start runs backwards automatically for a pre-programmed time at each start-up. This is an important function for cooling units, as it allows accumulated dust to be blown from the heat exchanger of the condenser – for long-lasting high cooling capacity.

### iQ<sup>2</sup> reverse on demand.

With the iQ<sup>2</sup> reverse on demand, you determine the time and duration of the reverse operation. For example, you can use the defrost cycle of the evaporator to eliminate dust from the heat exchanger of the condenser.

### iQ<sup>2</sup> two speeds.

The special performance feature of the iQ<sup>2</sup> two speeds is its two factory-programmed speed steps. For example, if you want your application to run in different daytime and nighttime modes to save additional energy, it is the right choice.

### General overview of data: iQ and iQ<sup>2</sup>

<b>Material:</b>	Die-cast aluminium housing	<b>Protection class:</b>	I, for iQ <sup>2</sup> plastic housing II on request
<b>Direction of air flow:</b>	Sucking or blowing (depending on axial impeller used)	<b>Approvals:</b>	UL, TÜV in accordance with DIN EN 60335-2-24, DIN EN 60335-2-89, DIN EN 60075-15, in progress for iQ <sup>2</sup>
<b>Direction of rotation:</b>	Counterclockwise, seen on shaft end	<b>Mounting attachment parts:</b>	Guard grille and wall ring are attached to the projecting thread ends on the A side
<b>System of protection:</b>	IP54	<b>Axial impeller attachment:</b>	A plastic adapter with catching peg and M4 screw is used to secure the impeller on the motor shaft
<b>Insulation class:</b>	"H"		
<b>Mounting position:</b>	Any		
<b>Mode of operation:</b>	Continuous operation (S1)		
<b>Bearings:</b>	Maintenance-free ball bearings		
<b>Motor protection:</b>	Via electronics		
<b>Electrical connection:</b>	Mains cable		

# iQ – Intelligence that pays

## A quick example calculation:

A typical supermarket operates 200 AC fans with 200 mm blades (blade angle 28°) in its refrigeration units. If the shaded-pole motors were to be replaced by iQ or iQ<sup>2</sup> motors, the energy consumption would be reduced by 39 megawatt hours. That is an annual saving of more than 5.000 euros\* and a good 23 tonnes of CO<sub>2</sub>.

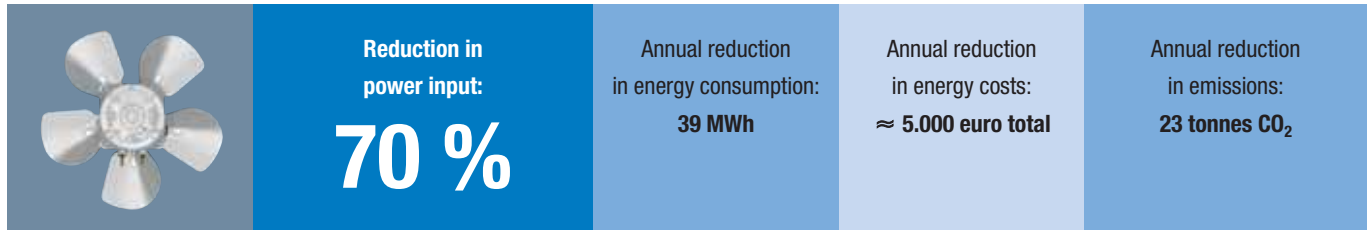

\*Assumptions: electricity price 0.13 euros per kWh, continuous operation 24 hours a day, 365 days a year

If you look at the figures for the iQ-motor over a prolonged period, its considerable energy-savings potential becomes especially obvious.

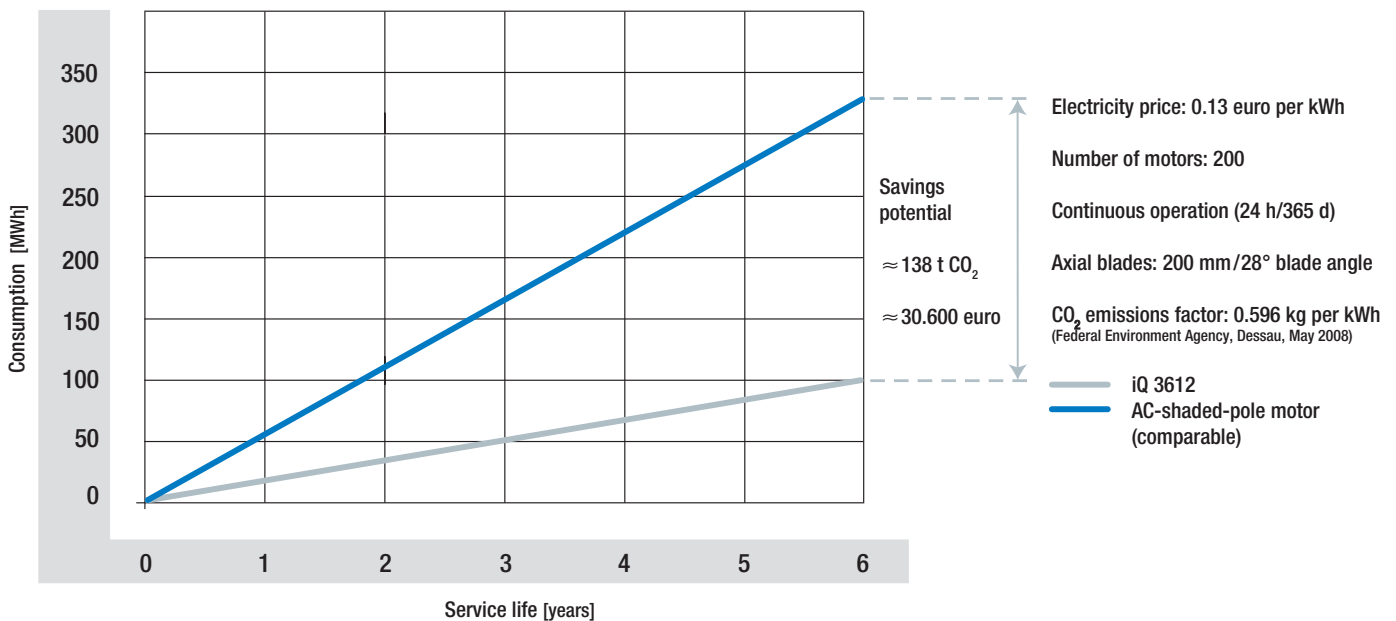

## iQ motor in energy-saving calculator:

How much energy and money could an iQ motor save in your company? By what amount could you decrease CO<sub>2</sub> emissions in the process? You can get a good idea of this with the ebm-papst energy savings calculator at [www.greentech.info](http://www.greentech.info). Go for your energy cost calculation there and the numbers will speak for themselves!

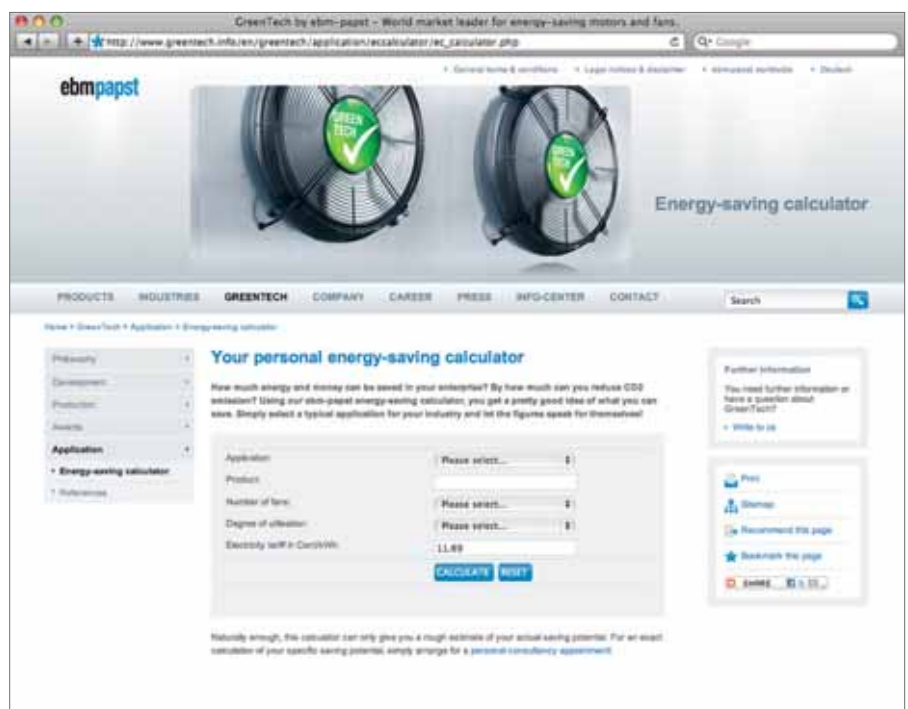

# Technical data

Nominal data		Nominal voltage	Frequency	Speed/rpm	Output power	Perm. amb. temp.	Mass	Dimensions		
Type	Features	V	Hz	rpm	W	°C	kg	a	b	c
iQ/iQ <sup>2</sup> 3608	Standard, ROS, ROD, 2 Speeds	220-240	50/60	1300	5	-40..+50	0,5	74	43,5	30,5
		115*	50/60	1550	5	-40..+50	0,5			
	Hybrid	220-240	50/60	1300	5	-40..+50	0,4			
		115*	50/60	1550	5	-40..+50	0,4			
iQ/iQ <sup>2</sup> 3612	Standard, ROS, ROD, 2 Speeds	220-240	50/60	1300	15	-40..+50	0,6	82	43,5	30,5
		115*	50/60	1550	15	-40..+50	0,6			
	Hybrid	220-240	50/60	1300	15	-40..+50	0,5			
		115*	50/60	1550	15	-40..+50	0,5			
	24 V	24	--	1300	11	-40..+50	0,6			
		24	--	400-1300	11	-40..+50	0,6			
iQ/iQ <sup>2</sup> 3620	Standard, ROS, ROD, 2 Speeds	220-240	50/60	1300	20	-40..+50	0,8	90	51,5	38,5
		115*	50/60	1550	20	-40..+50	0,8			
	Hybrid	220-240	50/60	1300	20	-40..+50	0,7			
		115*	50/60	1550	20	-40..+50	0,7			
	24 V	24	--	1300	15,5	-40..+50	0,8			
		24	--	400-1300	15,5	-40..+50	0,8			

subject to alterations

\*With 2 Speeds: upper speed

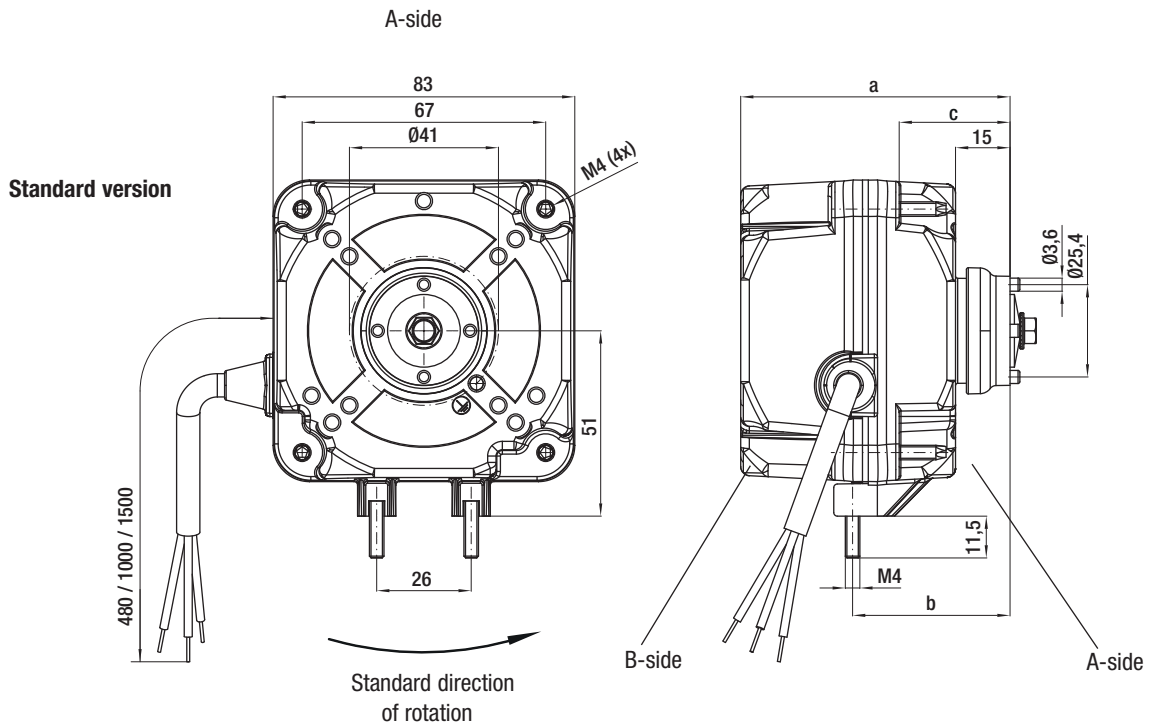

**Multi function version  
(only iQ 3612)**

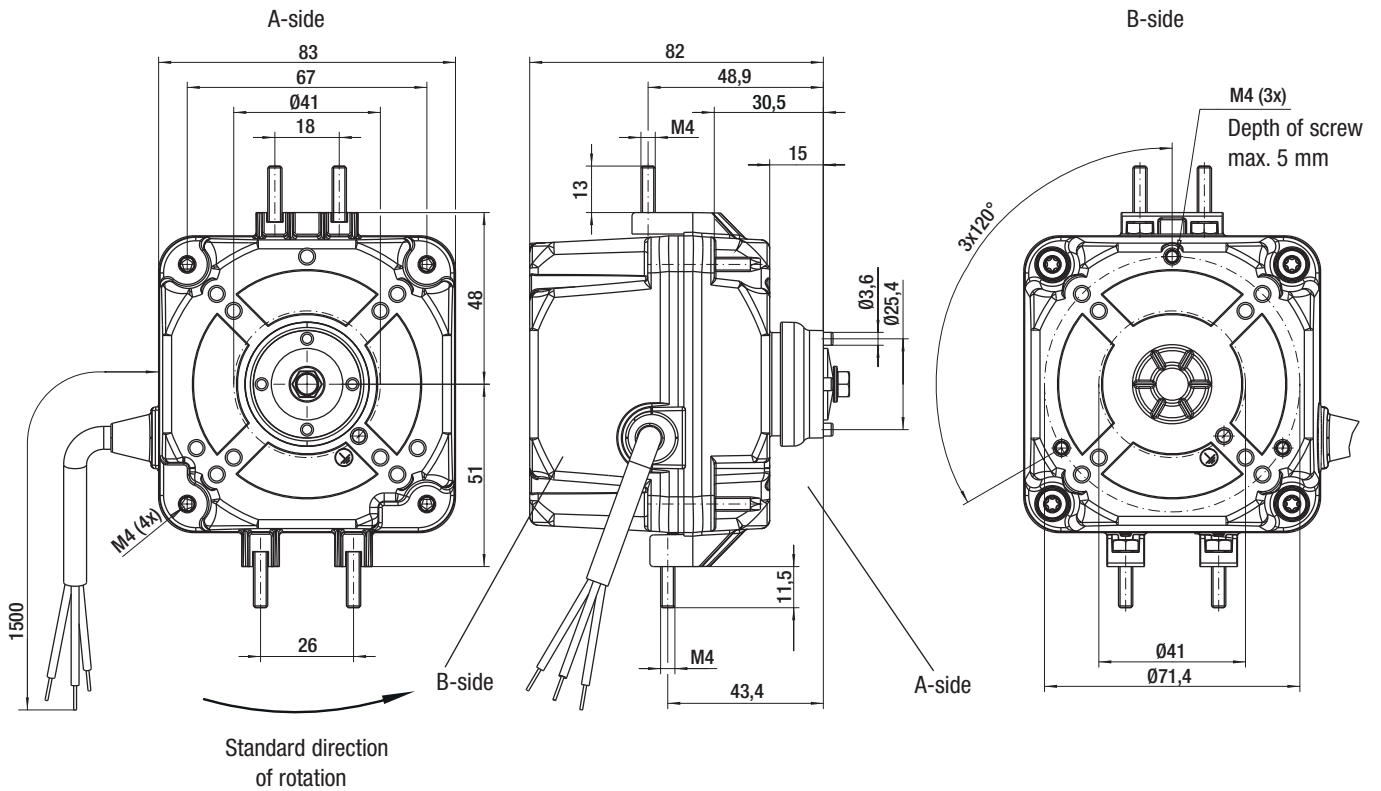

**24 V version; 400 - 1300 rpm; 0-10 V interface**  
Speed vs. control voltage:

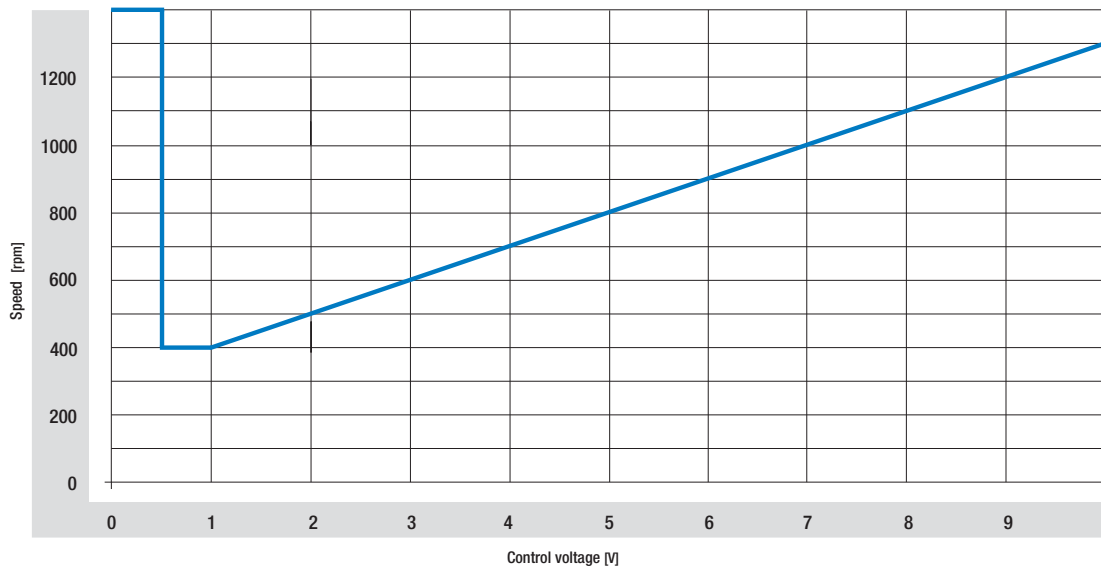

# iQ/iQ<sup>2</sup>-motor – combination with axial impellers

Power input and air flow



Motor	Axial impeller diameter	Axial impeller blade angle	Curves	Input power running at full throttle	Input power running at free air	Air flow running at free air at n=1300 rpm
iQ/iQ <sup>2</sup> 3608	mm	°		W	W	m <sup>3</sup> /h
	154	22	A	3,0	2,0	170
	154	28		3,8	2,8	190
	154	34		4,1	3,3	220
	172	22	B	4,6	2,6	230
	172	28		6,1	3,8	270
	172	34		7,8	5,0	310
	200	22	C	9,2	4,5	360
	200	28		9,2	5,5	410
iQ/iQ <sup>2</sup> 3612	mm	°		W	W	m <sup>3</sup> /h
	172	28	B	4,2	2,9	270
	172	34		5,7	3,8	310
	200	22	D	5,1	3,4	360
	200	28		8,3	5,3	410
	200	34		12,1	7,3	470
	230	22	E	9,6	6,0	520
	230	28		19,0	13,1	710
	230	34		20,5	16,9	750
	254	22	F	21,2	11,3	710
	254 *	28		19,3	21,2	980
iQ/iQ <sup>2</sup> 3620	mm	°		W	W	m <sup>3</sup> /h
	230	22	E	16,1	8,3	520
	230	28		21,2	11,9	710
	230	34		25,0	13,9	750
	254	22	G	26,5	12,3	710
	254	28		27,4	23,1	980
	254 *	34		25,7	28,4	1010
	300 *	22	H	23,7	24,3	1380

subject to alterations

\* Depending on back pressure, full nominal speed of 1300 min<sup>-1</sup> is not reached to some part. Depending on mounting situation and version, a speed of approx. 1200 min<sup>-1</sup> (+/- 100 min<sup>-1</sup>) is reached. Due to the intelligent electronics, however, safe (permanent) operation is still guaranteed.

## Power ratings (220 - 240 V design):

Power input and air flow at 230 V / 50 Hz and a constant speed of 1300 min<sup>-1</sup>.



# iQ/iQ<sup>2</sup>-motor

Air performance curves measured in wall ring, at a constant speed of 1,300 rpm.

iQ/iQ<sup>2</sup> 3608, Ø 154

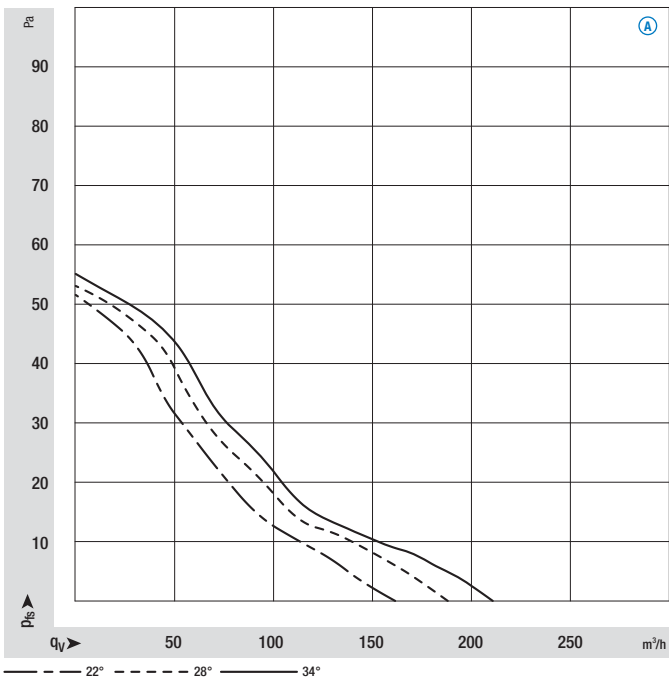

iQ/iQ<sup>2</sup> 3608 / 3612, Ø 172

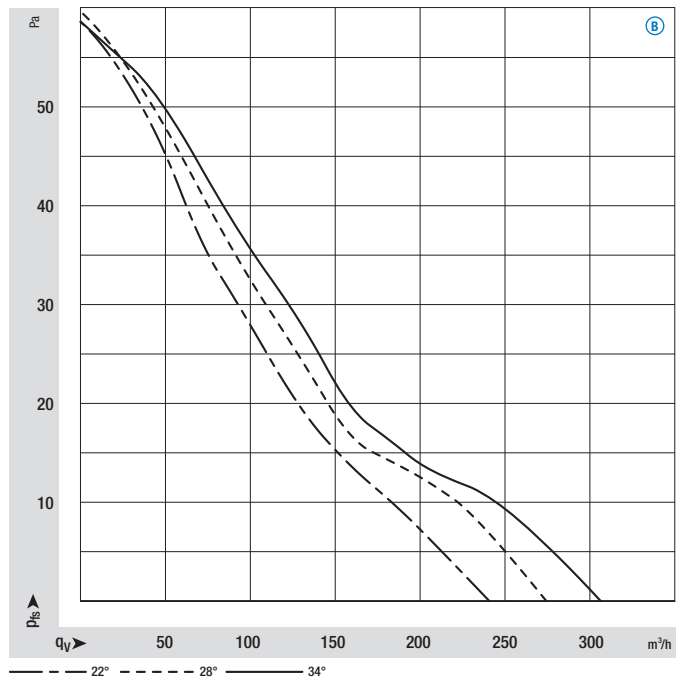

iQ/iQ<sup>2</sup> 3608, Ø 200

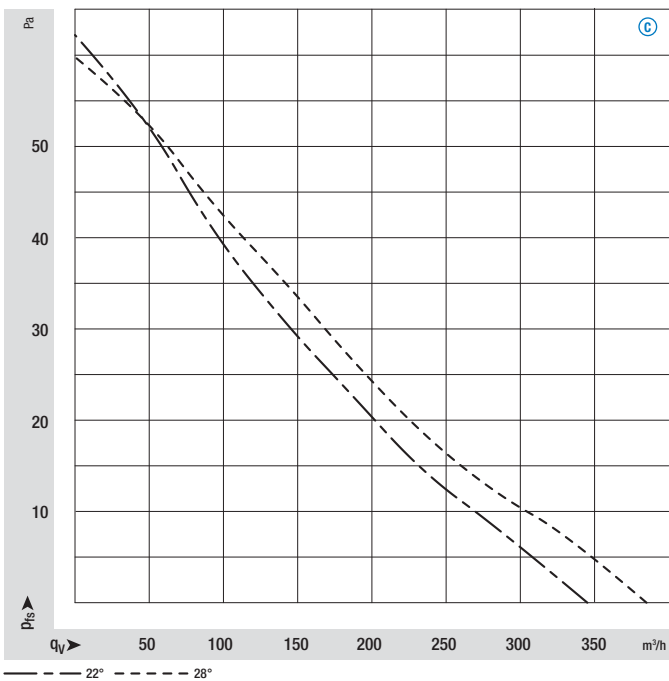

iQ/iQ<sup>2</sup> 3612, Ø 200

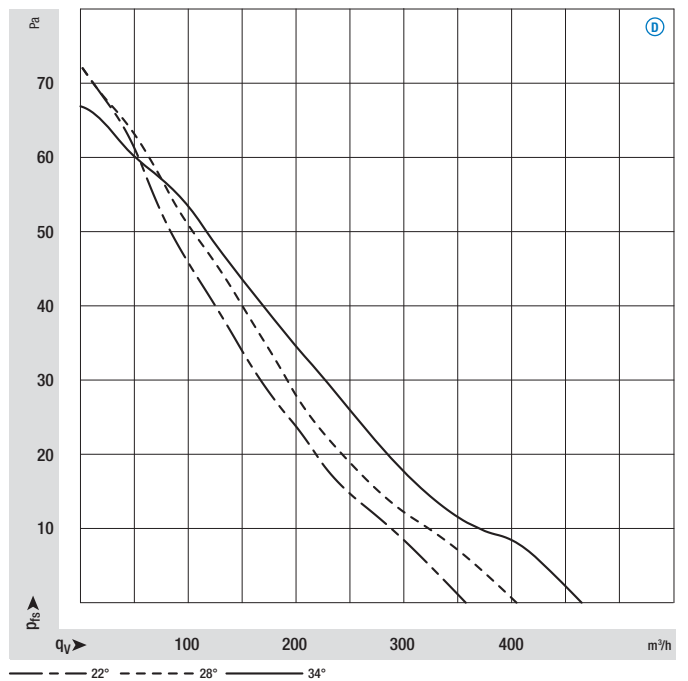



iQ/iQ<sup>2</sup> 3612 / 3620, Ø 230

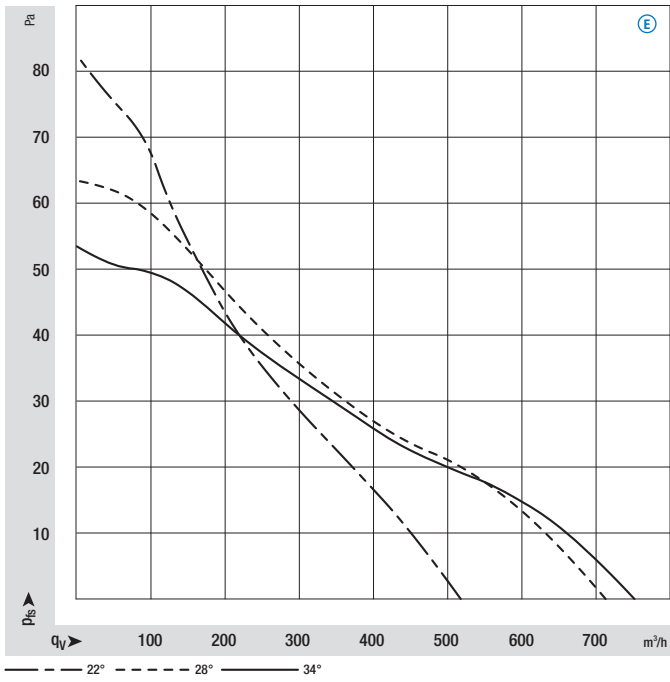

iQ/iQ<sup>2</sup> 3612, Ø 254

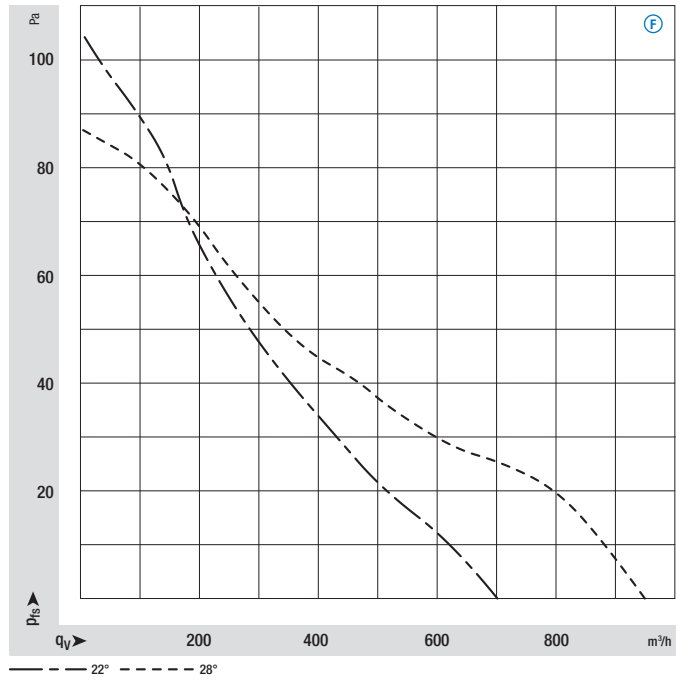

iQ/iQ<sup>2</sup> 3620, Ø 254

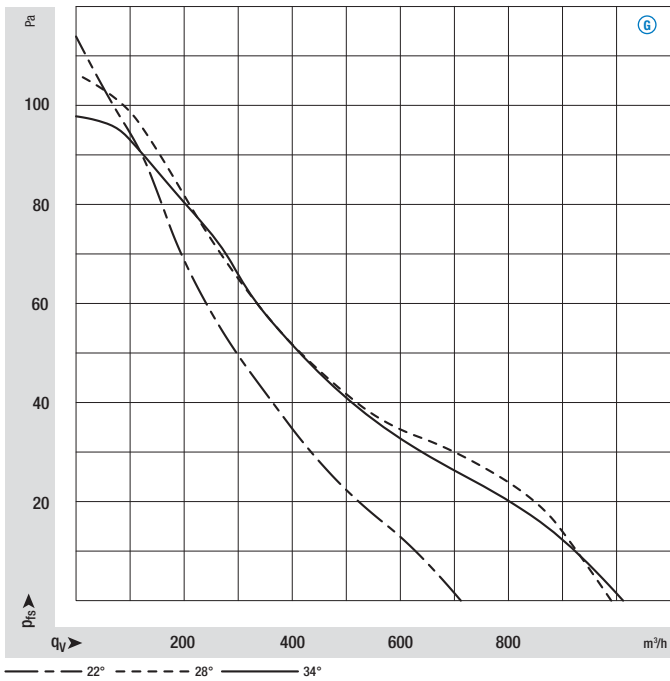

iQ/iQ<sup>2</sup> 3620, Ø 300

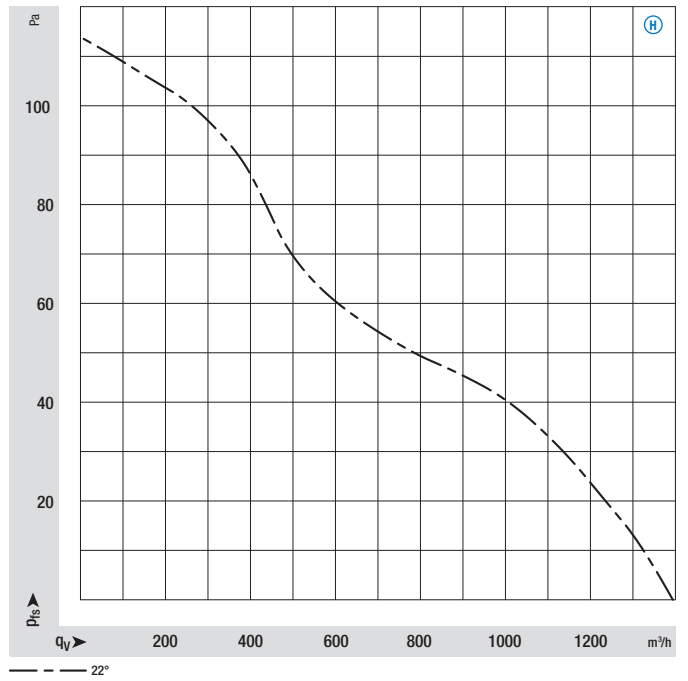

# Axial impellers

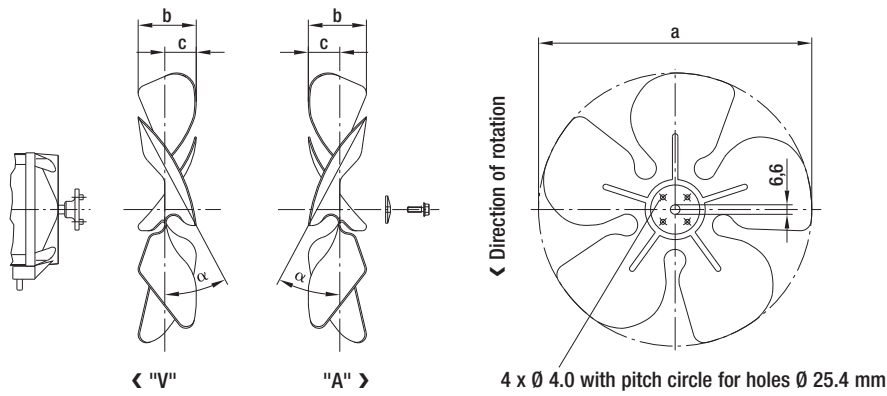

– Material: Sheet aluminium

## Axial impellers

Part no. for dir. of air flow "V"	Part no. for dir. of air flow "A"	Blade angle $\alpha$	a	b	c
27453.34001	27453.34201	$22^\circ \pm 1^\circ 30'$	154,0	27,5	14,0
27453.34002	27453.34202	$28^\circ \pm 1^\circ 30'$	154,0	32,0	16,0
27453.34003	27453.34203	$34^\circ \pm 1^\circ 30'$	154,0	37,0	18,0
27453.34004	27453.34204	$22^\circ \pm 1^\circ 30'$	172,0	31,0	14,5
27453.34005	27453.34205	$28^\circ \pm 1^\circ 30'$	172,0	36,0	17,0
27453.34006	27453.34206	$34^\circ \pm 1^\circ 30'$	172,0	42,0	21,0
27453.34007	27453.34207	$22^\circ \pm 1^\circ 30'$	200,0	32,0	15,5
27453.34008	27453.34208	$28^\circ \pm 1^\circ 30'$	200,0	37,5	18,0
27453.34009	27453.34209	$34^\circ \pm 1^\circ 30'$	200,0	45,0	22,0
27453.34010	27453.34210	$22^\circ \pm 1^\circ 30'$	230,0	35,0	17,5
27453.34011	27453.34211	$28^\circ \pm 1^\circ 30'$	230,0	43,0	21,5
27453.34012	27453.34212	$34^\circ \pm 1^\circ 30'$	230,0	50,0	24,0
27453.34013	27453.34213	$22^\circ \pm 1^\circ 30'$	254,0	37,0	19,0
27453.34014	27453.34214	$28^\circ \pm 1^\circ 30'$	254,0	45,0	23,5
27453.34015	27453.34215	$34^\circ \pm 1^\circ 30'$	254,0	52,0	26,0
27453.34016	27453.34216	$22^\circ \pm 1^\circ 30'$	300,0	43,0	21,5
27453.34017	27453.34217	$28^\circ \pm 1^\circ 30'$	300,0	53,5	26,5
27453.34018	27453.34218	$34^\circ \pm 1^\circ 30'$	300,0	61,0	30,0

subject to alterations

# Mounting bracket

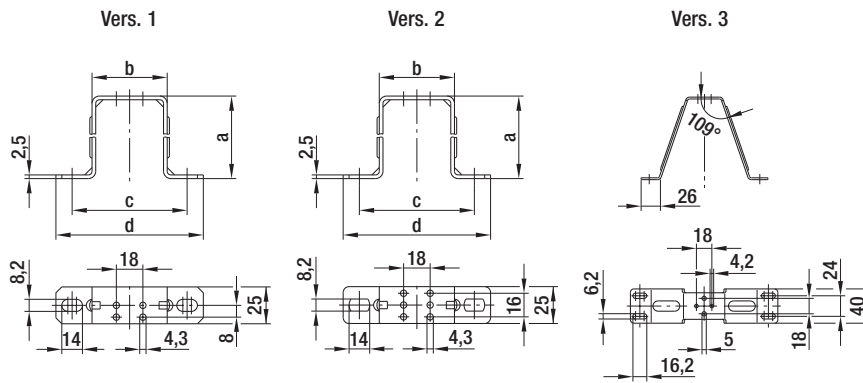

– **Material:** Sheet steel, galvanized and blue chromated

## Mounting bracket - foot measure 18 mm (multi-function design)

Part no.	Size	Vers.	a	b	c	d
27452.71002	172	1	56,0	51,0	78,0	100,0
27452.71005	200	1	67,0	51,0	78,0	100,0
27452.71003	230	1	74,5	51,0	78,0	100,0
27452.71004	254	2	85,5	51,0	78,0	100,0
27452.71001	300	3	112,0	—	150,0	172,0

subject to alterations

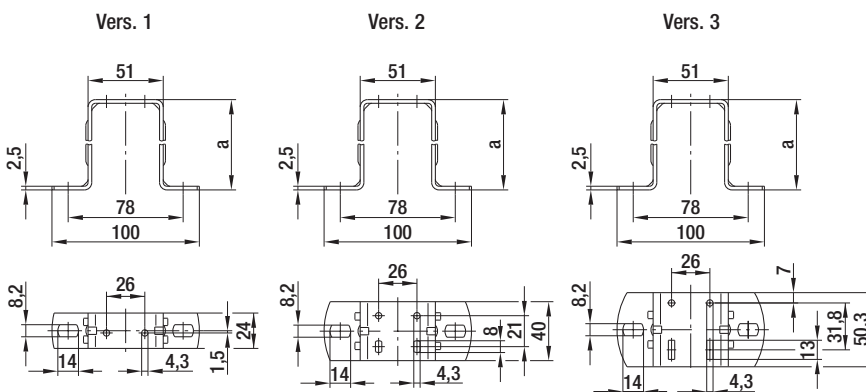

– **Material:** Sheet steel, galvanized and blue chromated

## Mounting bracket - foot measure 26 mm (standard design or multi-function design)

Part no.	Size	Vers.	a
27452.71201	154	1	39,0
27452.71202	172	1	52,0
27452.71203	200	1	72,0
	230	1	72,0
27452.71204	254	1	84,0
27452.71205	254	2	84,0
27452.71206	300	2	109,0
27452.71207	300	3	109,0

subject to alterations

# Guard grille

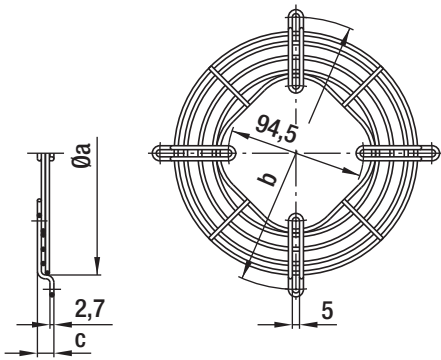

– **Material:** Steel, galvanized and blue chromated

## Guard grille

Part no.	Size	Max. blade angle $\alpha$ at "V"	Max. blade angle $\alpha$ at "A"	a	b	c
27452.70002	154	34°	34°	170,0	190,0	11,5
27452.70003	172	34°	34°	188,0	208,0	11,5
27452.70004	200	34°	28°	214,0	236,0	11,5
27452.70005	230	28°	28°	246,0	266,0	17,5
27452.70006	254	28°	28°	270,0	290,0	17,5
27452.70007	300	—	22°	324,0	344,0	17,5

subject to alterations

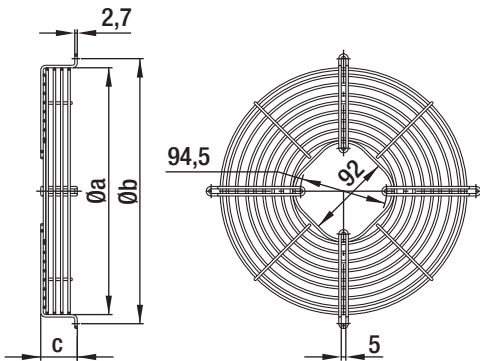

– **Material:** Steel, galvanized and blue chromated

## Basket guard grille

Part no.	Size	Max. blade angle $\alpha$ at "V"	Max. blade angle $\alpha$ at "A"	a	b	c
27452.70201	172	34°	34°	188,0	208,0	37,5
27452.70202	200	34°	28°	212,0	236,0	37,5
27452.70203	230	28°	28°	246,0	266,0	40,0
27452.70204	254	28°	28°	270,0	290,0	40,0
27452.70205	300	—	22°	324,0	344,0	46,8

subject to alterations

# Wall rings

– Material: Sheet steel, coated in grey plastic

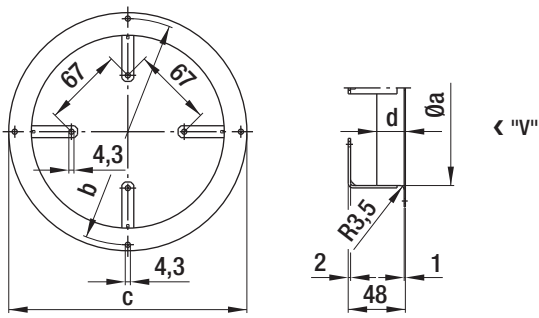

Wall rings, direction of air flow "V"

Part no. (sheet steel)	Part no. (plastic)	Size	Max. blade angle $\alpha$	a	b	c	d	d (plastic)
27452.70501	27452.70802	154	34°	164,0	190,0	200,0	24,0	26,0
27452.70502	27452.70803	172	34°	182,0	208,0	223,0	24,0	26,0
27452.70503	27452.70804	200	34°	210,0	236,0	246,0	24,0	26,0
27452.70504	---	230	28°	240,0	266,0	276,0	24,0	---
27452.70505	27452.70805	254	28°	264,0	290,0	300,0	24,0	26,0
27452.70506	27452.70806	300	22°	308,0	344,0	356,0	24,0	26,0

subject to alterations

– Material: Sheet steel, coated in grey plastic

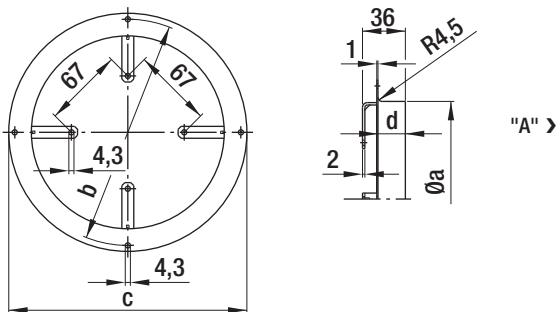

Wall rings, direction of air flow "A"

Part no. (sheet steel)	Part no. (plastic)	Size	Max. blade angle $\alpha$	a	b	c	d	d (plastic)
27452.70701	---	154	34°	162,0	190,0	200,0	24,0	---
27452.70702	---	172	34°	180,0	208,0	223,0	24,0	---
27452.70703	---	200	28°	208,0	236,0	246,0	24,0	---
27452.70704	---	230	28°	238,0	266,0	276,0	24,0	---
27452.70705	27452.70807	254	28°	262,0	290,0	300,0	24,0	26,0
27452.70706	---	300	22°	308,0	344,0	356,0	24,0	---

subject to alterations

# Technical parameters & scope



## High standards for all ebm-papst products

*Here at ebm-papst, we constantly strive to further improve our products in order to be able to offer you the best possible product for your application. Careful monitoring of the market ensures that technical innovations are reflected in the improvements of our products.*

*Based on the technical parameters listed below and the ambience you want our product to operate in, we here at ebm-papst can always work out the best solution for your specific application.*

## ■ General performance parameters

Any deviations from the technical data and parameters described here are listed on the product-specific data sheet.

### Type of protection

The type of protection is specified in the product-specific data sheets.

### Insulation class

The insulation class is specified in the product-specific data sheets.

### Mounting position

The mounting position is specified in the product-specific data sheets.

### Condensate discharge holes

Information on the condensate discharge holes is provided in the product-specific data sheets.

### Mode of operation

The mode of operation is specified in the product-specific data sheets.

### Protection class

The protection class is specified in the product-specific data sheets.

## Service life

The service life of ebm-papst products depends on two major factors:

- The service life of the insulation system
- The service life of the bearing system

The service life of the insulation system mainly depends on voltage level, temperature and ambient conditions, such as humidity and condensation. The service life of the bearing system depends mainly on the thermal load on the bearing.

The majority of our products use maintenance-free ball bearings for any mounting position possible. As an option, sleeve bearings can be used, which is indicated on the product-specific data sheet wherever applicable.

The service life L10 of the ball bearings can be taken as approx. 40,000 operating hours at an ambient temperature of 40 °C, yet this estimate can vary according to the actual ambient conditions.

We will gladly provide you with a lifetime calculation taking into account your specific operating conditions.

## Motor protection / thermal protection

Information on motor protection and thermal protection is provided in the product-specific data sheets.

Depending on motor type and field of application, the following protective features are realised:

- Thermal overload protection (TOP), either in-circuit or external
- PTC with electronic diagnostics
- Impedance protection
- Thermal overload protection (TOP) with electronic diagnostics
- Current limitation via electronics

If an external TOP is connected, the customer has to make sure to connect a conventional trigger device for switching it off.

Products without fitted TOP and without protection against improper use, a motor protection complying with the valid standards has to be installed.

*Left: Endurance test room  
Middle: Shock test  
Right: Chamber test rig*



### ■ Mechanical strain / performance parameters

All ebm-papst products are subjected to comprehensive tests complying with the normative specifications. In addition to this, the tests also reflect the vast experience and expertise of ebm-papst.

#### **Vibration test**

Vibration tests are carried out in compliance with

- Vibration test in operation according to DIN IEC 68, parts 2-6
- Vibration test at standstill according to DIN IEC 68, parts 2-6

#### **Shock load**

Shock load tests are carried out in compliance with

- Shock load according to DIN IEC 68, parts 2-27

#### **Balancing quality**

Testing the balancing quality is carried out in compliance with

- Residual imbalance according to DIN ISO 1940
- Standard balancing quality level G 6.3

Should you require a higher balancing quality level for your specific application, please let us know and specify this when ordering your product.

### ■ Chemo-physical strain / performance parameters

Should you have questions about chemo-physical strain, please direct them to your ebm-papst contact.

### ■ Fields of application, industries and applications

Our products are used in various industries and applications:

Ventilation, air-conditioning and refrigeration technology, clean room technology, automotive and rail technology, medical and laboratory technology, electronics, computer and office technology, telecommunications, household appliances, heating, machines and plants, drive engineering. Our products are not designed for use in the aviation and aerospace industry!

### ■ Legal and normative directives

The products described in this catalogue are designed, developed and produced in keeping with the standards in place for the relevant product and, if known, the conditions governing the relevant fields of application.

#### **Standards**

Information on standards is provided in the product-specific data sheets.

#### **EMC**

Information on EMC standards is provided in the product-specific data sheets.

Complying with the EMC standards has to be established on the final appliance, as different mounting situations can result in changed EMC properties.

#### **Leakage current**

Information on the leakage current is provided in the product-specific data sheets.

Measuring is according to IEC 60990.

#### **Approvals**

In case you require a specific approval for your ebm-papst product (VDE, UL, GOST, CCC, CSA, etc.) please let us know.

Most of our products can be supplied with the relevant approval.

Information on existing approvals is provided in the product-specific data sheets.

### ■ Air performance measurements

All air performance measurements are carried out on suction side and on chamber test beds conforming to the specifications as per ISO 5801 and DIN 24163. The fans under test are installed in the measuring chamber at free air intake and exhaust (installation category A) and are operated at nominal voltage, with AC also at nominal frequency, and without any additional components such as guard grilles.

As required by the standard, the air performance curves correspond to an air density of 1.2 kg/m<sup>3</sup>.

Room for precision noise measuring



### Measurement conditions for air and noise measurement

ebm-papst products are measured under the following conditions:

- Axial and diagonal fans in direction of rotation “V” in full nozzle and without guard grille
- Backward curved centrifugal fans, free-running and with inlet nozzle
- Forward curved single and dual inlet centrifugal fans with housing

### Noise measurements

All noise measurements are carried out in low-reflective test rooms with reverberant floor. Thus the ebm-papst acoustic test chambers meet the requirements of precision class 1 according to DIN EN ISO 3745. For noise measurement, the fans being tested are placed in a reverberant wall and operated at nominal voltage (for AC, also at nominal frequency) without additional attachments such as the guard grille.

### Sound pressure level and sound level

All acoustic values are established according to ISO 13347, DIN 45635 and ISO 3744/3745 to accuracy class 2 and given in A-rated form.

When the sound pressure level ( $L_p$ ) is measured, the microphone is on the intake side of the fan being tested, usually at a distance of 1 m on the fan axis.

To measure the sound power level ( $L_w$ ), 10 microphones are distributed over an enveloping surface on the intake side of the fan being tested (see graphic). The sound power level measured can be roughly calculated from the sound pressure level by adding 7 dB.

Measuring configuration as per ISO 13347-3 respectively DIN 45635-38:

- 10 measuring points

$$d \geq D$$

$$h = 1,5d \dots 4,5d$$

$$\text{Measurement area } S = 6d^2 + 7d(h + 1,5d)$$

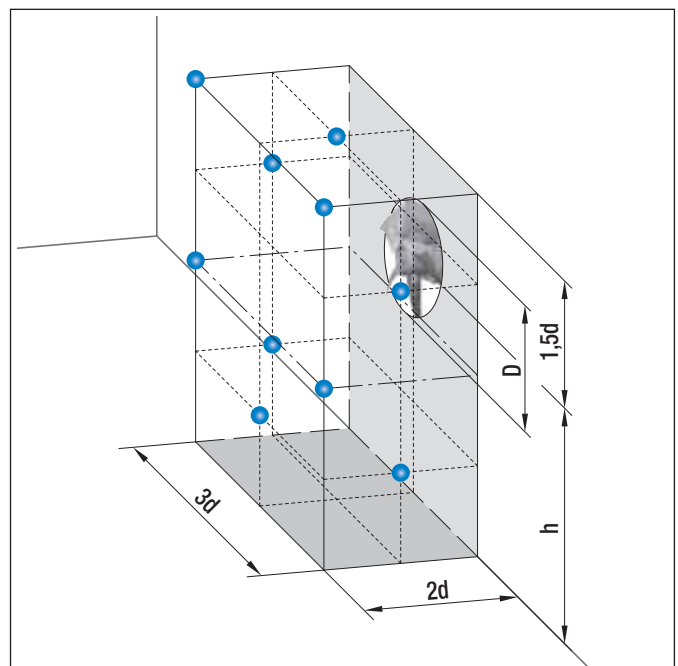



### Combined level of multiple same-level sound sources

Adding 2 noise sources with the same level results in a level increase of approx. 3 dB.

The noise characteristics of multiple identical fans can be determined in advance based on the noise values specified in the data sheet. This is shown in the diagram opposite.

Example: 8 A3G800 axial fans are on a condenser. According to the data sheet, the sound pressure level of a fan is approximately 75 dB(A). The level increase measured from the diagram is 9 dB. Thus the overall sound level of the installation can be expected to be 84 dB(A).

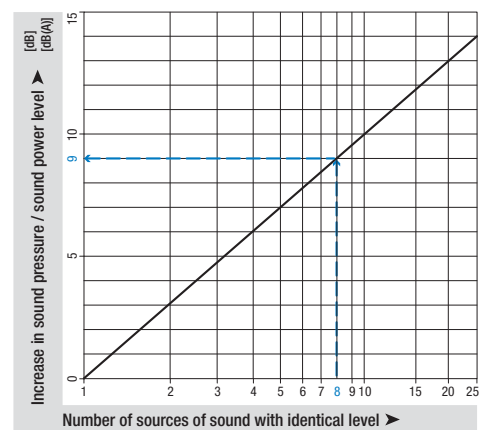

### Combined level of two different-level sound sources

The acoustic performance of two different fans can be predetermined based on the sound levels given in the data sheet. This is shown in the diagram opposite.

Example: There is an axial fan A3G800 with a sound pressure level of 75 dB(A) at the operating point and an axial fan A3G710 with 71 dB(A) in a ventilation unit. The level difference is 4 dB. The level increase can now be read in the diagram as approx. 1.5 dB. This means that the overall sound level of the unit can be expected to be 76.5 dB(A).

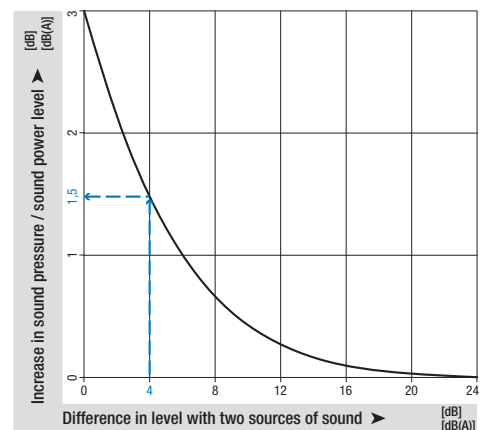



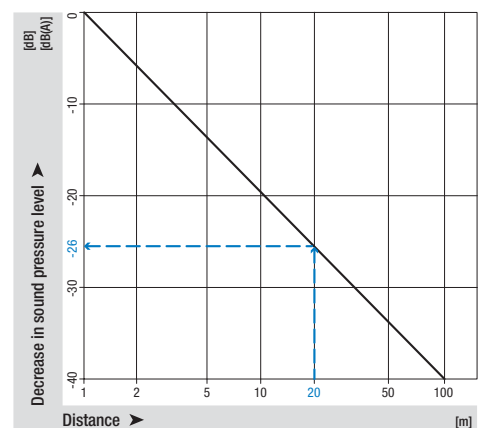

### Distance laws

Sound power level is independent of distance to the sound source. In contrast to this, sound pressure level decreases the further away the noise source is. The adjacent diagram shows the decrease in level under far sound field conditions. Far sound field conditions apply whenever the distance between microphone and fan is big when compared to fan diameter and wavelength to be considered. For more information on far sound field, please consult the relevant literature on this complex topic. Per doubling of distance, the level in the far sound field decreases by 6 dB. In the near field of the fan, other correlations apply and the decrease in levels can be considerably smaller. The following example only applies to far sound field conditions and can vary strongly depending on the installation effects:

With an axial fan A3G300, a sound pressure level of 65 dB(A) was measured at a distance of 1 m. According to the adjacent diagram, at a distance of 20 m we would get a reduction by 26 dB, i.e. a sound pressure level of 39 dB(A).



-  fan agent
-  compact fan agent
-  motor specialist
-  motor agent

# ebm-papst in Germany

## Germany

### ebm-papst Muldingen GmbH & Co. KG

Bachmühle 2  
D-74673 Muldingen  
Phone +49 7938 81-0  
Fax +49 7938 81-110  
info1@de.ebmpapst.com

www.ebmpapst.com

### ebm-papst St. Georgen GmbH & Co. KG

Hermann-Papst-Straße 1  
D-78112 St. Georgen  
Phone +49 7724 81-0  
Fax +49 7724 81-1309  
info2@de.ebmpapst.com

www.ebmpapst.com

### ebm-papst Landshut GmbH

Hofmark-Aich-Straße 25  
D-84030 Landshut  
Phone +49 871 707-0  
Fax +49 871 707-465  
info3@de.ebmpapst.com

www.ebmpapst.com

 **Berlin**  
 Dipl.-Ing. (TH) Jens Duchow  
Händelstraße 7  
 D-16341 Panketal  
Phone +49 30 944149-62  
Fax +49 30 944149-63  
Jens.Duchow@de.ebmpapst.com

 **Bielefeld**  
 Dipl.-Ing. (FH) Wolf-Jürgen Weber  
Niehausweg 13  
 D-33739 Bielefeld  
Phone +49 5206 91732-31  
Fax +49 5206 91732-35  
Wolf-Juergen.Weber@de.ebmpapst.com

 **Dortmund**  
 Dipl.-Ing. (FH) Hans-Joachim Pundt  
Auf den Steinern 3  
 D-59519 Möhnese-Völlinghausen  
Phone +49 2925 800-407  
Fax +49 2925 800-408  
Hans-Joachim.Pundt@de.ebmpapst.com

 **Frankfurt**  
 Dipl.-Ing. Christian Kleffmann  
Dr.-Hermann-Krause-Straße 23  
 D-63452 Hanau  
Phone +49 6181 1898-12  
Fax +49 6181 1898-13  
Christian.Kleffmann@de.ebmpapst.com

 **Halle**  
 Dipl.-Ing. (TU) Michael Hanning  
Lercheneck 4  
 D-06198 Salzatal / OT Lieskau  
Phone +49 345 55124-56  
Fax +49 345 55124-57  
Michael.Hanning@de.ebmpapst.com

 **Hamburg**  
 Ingenieurbüro Breuell GmbH  
Ing. Dirk Kahl  
 Elektroingenieur  
Grützmühlenweg 48  
D-22339 Hamburg  
Phone +49 40 538092-19  
Fax +49 40 538092-84  
Dirk.Kahl@de.ebmpapst.com

 **Heilbronn / Heidelberg**  
 Dipl.-Ing. Mark Gartner  
Gehweg 12  
 D-74199 Unterheinriet  
Phone +49 7130 404569-1  
Fax +49 7130 404569-2  
Mark.Gartner@de.ebmpapst.com

 **Kassel**  
 Dipl.-Ing. (FH) Ralph Brück  
Hoherainstraße 3 b  
 D-35075 Gladenbach  
Phone +49 6462 4071-10  
Fax +49 6462 4071-11  
Ralph.Brueck@de.ebmpapst.com

 **Koblenz**  
 Winfried Schaefer  
Hinter der Kirch 10  
 D-56767 Uersfeld  
Phone +49 2657 16-96  
Fax +49 2657 16-76  
Winfried.Schaefer@de.ebmpapst.com

 **Munich**  
 Dipl.-Wirt.-Ing. (FH) Jens Peter  
Landsbergerstraße 14  
 D-86932 Pürgen  
Phone +49 8196 99877-54  
Fax +49 8196 99877-55  
Jens.Peter@de.ebmpapst.com

 **Nuremberg**  
 Dipl.-Wirt.-Ing. (FH) Axel Resch  
Dr.-August-Koch-Str. 1  
 D-91639 Wolframs-Eschenbach  
Phone +49 9875 9783-170  
Fax +49 9875 9783-171  
Axel.Resch@de.ebmpapst.com

 **Offenburg**  
 Dipl.-Ing. (FH) Ralf Braun  
Hubeneck 21  
 D-77704 Oberkirch  
Phone +49 7802 9822-52  
Fax +49 7802 9822-53  
Ralf.Braun@de.ebmpapst.com

 **Stuttgart**  
 Dipl.-Ing. (FH) Rudi Weinmann  
Hindenburgstraße 100/1  
 D-73207 Plochingen  
Phone +49 7153 9289-80  
Fax +49 7153 9289-81  
Rudi.Weinmann@de.ebmpapst.com

 **Ulm**  
 M.Sc. Reinhard Sommerreißer  
Am Silbermannpark 10  
 D-86161 Augsburg  
Phone +49 821 6610-7023  
Fax +49 821 6610-7024  
Reinhard.Sommerreisser@de.ebmpapst.com

## Distributors

 **Frankfurt**  
R.E.D. Handelsgesellschaft mbH  
Gutenbergstraße 3  
D-63110 Rodgau - Jügesheim  
Phone +49 6106 841-0  
Fax +49 6106 841-111  
info@red-elektromechanik.de  
www.red-elektromechanik.de

 **Hamburg**  
Breuell + Hilgenfeldt GmbH  
Grützmühlenweg 48  
D-22339 Hamburg  
Phone +49 40 538092-20  
Fax +49 40 538092-84  
info@breuell-hilgenfeldt.de

 **Munich**  
A. Schweiger GmbH  
Ohmstraße 1  
D-82054 Sauerlach  
Phone +49 8104 897-0  
Fax +49 8104 897-90  
info@schweiger-gmbh.de  
www.schweiger-gmbh.com

● **Express Service-Center** (1 to 5 pieces)

 **North**  
 Breuell + Hilgenfeldt GmbH  
Grützmühlenweg 48  
 D-22339 Hamburg  
Phone +49 40 538092-20  
Fax +49 40 538092-84  
ebmpapst@breuell-hilgenfeldt.de

 **South**  
 HDS Ventilatoren Vertriebs GmbH  
Glaswiesenstraße 1  
D-74677 Dörzbach  
Phone +49 7937 80355-20  
Fax +49 7937 80355-25  
info@hds-gmbh.net  
www.hds-gmbh.net

## Europe



### Austria

ebm-papst Motoren & Ventilatoren GmbH  
Straubingstraße 17  
A-4030 Linz  
Phone +43 732 321150-0  
Fax +43 732 321150-20  
info@at.ebmpapst.com  
www.ebmpapst.at



### Belarus

ebm-papst Bel AgmbH  
P.O. Box 117  
BY-220138 Minsk  
Phone +375 17 3851556  
Fax +375 17 3851556  
info@by.ebmpapst.com  
www.ebmpapst.by



### Belgium

ebm-papst Benelux B.V.  
Sales office Belgium-Luxemburg  
Romeinsestraat 6/0101  
Research Park Haasrode  
B-3001 Heverlee-Leuven  
Phone +32 16 396-200  
Fax +32 16 396-220  
info@be.ebmpapst.com  
www.ebmpapst.be



### Bulgaria

ebm-papst Romania S.R.L.  
Str. Tarnavei No. 20  
RO-500327 Brasov  
Phone +40 268 331859  
Fax +40 268 312805  
dudasludovic@xnet.ro



### Croatia

ebm-papst Industries Kft.  
Ezred u. 2.  
H-1044 Budapest  
Phone +36 1 8722-190  
Fax +36 1 8722-194  
office@hu.ebmpapst.com



### Czech Republic / Slovakia

ebm-papst CZ s.r.o.  
Kaštanová 34a  
CZ-620 00 Brno  
Phone +420 544 502-411  
Fax +420 547 232-622  
info@ebmpapst.cz  
www.ebmpapst.cz



### Denmark

ebm-papst Denmark ApS  
Vallensbækvej 21  
DK-2605 Brøndby  
Phone +45 43 631111  
Fax +45 43 630505  
mail@dk.ebmpapst.com  
www.ebmpapst.dk



### Estonia

ebm-papst Oy, Eesti Filiaal  
Kesk tee 13  
Aaviku küla, Jüri Tehnopark  
EST-75301 Rae Vald, Harjumaa  
Phone +372 65569-78  
Fax +372 65569-79  
www.ebmpapst.ee



### Finland

ebm-papst Oy  
Puistotie 1  
FIN-02760 Espoo  
Phone +358 9 887022-0  
Fax +358 9 887022-13  
mailbox@ebmpapst.fi  
www.ebmpapst.fi



### France

ebm-papst sarl  
ZI Nord - rue A. Mohler  
BP 62  
F-67212 Obernai Cedex  
Phone +33 820 326266  
Fax +33 3 88673883  
info@ebmpapst.fr  
www.ebmpapst.fr



### Greece

Helcoma  
Th. Rotas & Co OE  
Davaki 65  
GR-17672 Kallithea-Attiki  
Phone +30 210 9513-705  
Fax +30 210 9513-490  
contact@helcoma.gr  
www.helcoma.gr



### Hungary

ebm-papst Industries Kft.  
Ezred u. 2.  
H-1044 Budapest  
Phone +36 1 8722-190  
Fax +36 1 8722-194  
office@hu.ebmpapst.com



### Iceland

RJ Engineers  
Stangarhyl 1a  
IS-110 Reykjavik  
Phone +354 567 8030  
Fax +354 567 8015  
rj@rj.is  
www.rj.is



### Ireland

ebm-papst UK Ltd.  
Chelmsford Business Park  
GB-Chelmsford Essex CM2 5EZ  
Phone +44 1245 468555  
Fax +44 1245 466336  
sales@uk.ebmpapst.com  
www.ebmpapst.co.uk



### AuBren Limited

Portlaoise Business & Technology Park  
Mountrath Road  
IRL-Portlaoise, Co. Laois  
Phone +353 57 8664343  
Fax +353 57 8664346  
sales@ie.aubren.com  
www.aubren.com







### Italy

ebm-papst Srl  
Via Cornaggia 108  
I-22076 Mozzate (Co)  
Phone +39 0331 836201  
Fax +39 0331 821510  
info@it.ebmpapst.com  
www.ebmpapst.it



### Macedonia

ebm-papst Industries Kft.  
Ezred u. 2.  
H-1044 Budapest  
Phone +36 1 8722-190  
Fax +36 1 8722-194  
office@hu.ebmpapst.com

-  fan agent
-  compact fan agent
-  motor specialist
-  motor agent

# ebm-papst in Europe

 **Netherlands**  
 ebm-papst Benelux B.V.  
 Engelseweg 127  
 NL-5705 AC Helmond  
 Phone +31 492 502-900  
 Fax +31 492 502-950  
 verkoop@nl.ebmpapst.com  
 www.ebmpapst.nl

 **Norway**  
 ebm-papst AS  
 P.B. 173 Holmlia  
 N-1203 Oslo  
 Phone +47 22 763340  
 Fax +47 22 619173  
 mailbox@ebmpapst.no  
 www.ebmpapst.no

 **Poland**  
 ebm-papst Polska Sp. z o.o.  
 ul. Annopol 4A  
 PL-03236 Warszawa  
 Phone +48 22 6757819  
 Fax +48 22 6769587  
 office@ebmpapst.pl  
 www.ebmpapst.pl

 **Portugal**  
 ebm-papst (Portugal), Lda.  
 Centro Empresarial de Alverca  
 Rua de Adarse, Vale D'Ervas  
 Corpo D / Fracção 3  
 P-2615-178 Alverca do Ribatejo  
 Phone +351 218 394 880  
 Fax +351 218 394 759  
 info@pt.ebmpapst.com  
 www.ebmpapst.pt

 **Romania**  
 ebm-papst Romania S.R.L.  
 Str. Tarnavei Nr. 20  
 RO-500327 Brasov  
 Phone +40 268 331859  
 Fax +40 268 312805  
 dadasludovic@xnet.ro

 **Russia**  
 ebm-papst Ural GmbH  
 Posadskaja-Strasse, 23(E), 3  
 RU-620102 Ekaterinburg  
 Phone +7 343 2338000  
 Fax +7 343 2337788  
 Konstantin.Molokov@ru.ebmpapst.com  
 www.ebmpapst.ur.ru

 ebm-papst Rus GmbH  
 proezd 4529, vladenie 5, stroenie 1  
 RU-141000 Mytistschi, Oblast Moskau  
 Phone +7 495 9807524  
 Fax +7 495 5140924  
 info@ebmpapst.ru  
 www.ebmpapst.ru



 **Serbia & Montenegro**  
 ebm-papst Industries Kft.  
 Ezred u. 2.  
 H-1044 Budapest  
 Phone +36 1 8722-190  
 Fax +36 1 8722-194  
 office@hu.ebmpapst.com

 **Spain**  
 ebm-papst Ibérica S.L.  
 Avda. del Sistema Solar, 29  
 E-28830 San Fernando de Henares (Madrid)  
 Phone +34 91 6780894  
 Fax +34 91 6781530  
 ventas@ebmpapst.es  
 www.ebmpapst.es

 **Sweden**  
 ebm-papst AB  
 Äggelundavägen 2  
 S-17562 Järfälla  
 Phone +46 10 4544400  
 Fax +46 8 362306  
 info@ebmpapst.se  
 www.ebmpapst.se

 **Switzerland**  
 ebm-papst AG  
 Rütisbergstrasse 1  
 CH-8156 Oberhasli  
 Phone +41 44 73220-70  
 Fax +41 44 73220-77  
 verkauf@ebmpapst.ch  
 www.ebmpapst.ch

 **Turkey**  
 Akantel Elektronik San. Tic. LTD. Sti.  
 Atatürk Organize Sanayi  
 Bölgesi 10007 SK. No.:6  
 TR-35620 Cigli-Izmir  
 Phone +90 232 3282090  
 Fax +90 232 3280270  
 akantel@akantel.com.tr  
 www.ebmpapst.com.tr

 **Ukraine**  
 ebm-papst Ukraine LLC  
 Lapse Boulevard, 4, Building 21  
 UA-03067 Kiev  
 Phone +38 044 2063091  
 Fax +38 044 2063091  
 mail@ebmpapst.ua  
 www.ebmpapst.ua

 **United Kingdom**  
 ebm-papst UK Ltd.  
 Chelmsford Business Park  
 GB-Chelmsford Essex CM2 5EZ  
 Phone +44 1245 468555  
 Fax +44 1245 466336  
 sales@uk.ebmpapst.com  
 www.ebmpapst.co.uk

 ebm-papst Automotive & Drives (UK) Ltd.  
 The Smithy  
 Fidlers Lane  
 GB-East Ilsley, Berkshire RG20 7LG  
 Phone +44 1635 2811-11  
 Fax +44 1635 2811-61  
 A&Dsales@uk.ebmpapst.com  
 www.ebmpapst-ad.com

# ebm-papst in America and Africa

## America



### Argentina



ebm-papst de Argentina S.A.  
Hernandarias 148 Lomas del Mirador  
Pcia. de Buenos Aires (1752)  
Phone +54 11 46576135  
Fax +54 11 46572092  
ventas@ar.ebmpapst.com  
www.ebmpapst.com.ar



### Brazil



ebm-papst Motores Ventiladores Ltda.  
Av. José Giorgi, 301 Galpões B6+B7  
Condominio Logical Center  
BR-06707-100 Cotia - São Paulo  
Phone +55 11 4613-8700  
Fax +55 11 4777-1456  
vendas@br.ebmpapst.com  
www.ebmpapst.com.br



### Canada



ebm-papst Canada Inc.  
1800 Ironstone Manor, Unit 2  
CDN-Pickering, Ontario, L1W3J9  
Phone +1 905 420-3533  
Fax +1 905 420-3772  
sales@ca.ebmpapst.com  
www.ebmpapst.ca



### Mexico



ebm Industrial S. de R.L. de C.V.  
Paseo de Tamarindos 400-A-5º Piso  
Col. Bosques de las Lomas  
MEX-Mexico 05120, D.F.  
Phone +52 55 3300-5144  
Fax +52 55 3300-5243  
sales@mx.ebmpapst.com  
www.ebmpapst.com.mx

## USA



ebm-papst Inc.  
P.O. Box 4009  
100 Hyde Road  
USA-Farmington, CT 06034  
Phone +1 860 674-1515  
Fax +1 860 674-8536  
sales@us.ebmpapst.com  
www.ebmpapst.us



ebm-papst Automotive & Drives, Inc.  
3200 Greenfield, Suite 255  
USA-Dearborn, MI 48120  
Phone +1 313 406-8080  
Fax +1 313 406-8081  
automotive@us.ebmpapst.com  
www.ebmpapst-automotive.us





## Africa



### South Africa



ebm-papst South Africa (Pty) Ltd.  
P.O. Box 3124  
1119 Yacht Avenue  
ZA-2040 Honeydew  
Phone +27 11 794-3434  
Fax +27 11 794-5020  
info@za.ebmpapst.com  
www.ebmpapst.co.za

-  fan agent
-  compact fan agent
-  motor specialist
-  motor agent

# ebm-papst in Asia and Australia

## Asia

 **China**  
 ebm-papst Ventilator (Shanghai) Co., Ltd.  
 No. 418, Huajing Road  
 WaiGaoQiao Free Trade Zone  
 No. 2001, Yang Gao (N) Road  
 VRC-200131 Shanghai, P.R. of China  
 Phone +86 21 5046-0183  
 Fax +86 21 5046-1119  
 sales@cn.ebmpapst.com  
 www.ebmpapst.com.cn

 **Hong Kong**  
 ebm-papst Hong Kong Ltd.  
 Unit No. 13,9 / F  
 Technology Park, 18 On Lai Street  
 Siu Lek Yuen, Shatin N.T.  
 Hong Kong - P.R. of China  
 Phone +852 2145-8678  
 Fax +852 2145-7678  
 info@hk.ebmpapst.com

 **India**  
 ebm-papst India Pvt. Ltd.  
 26/3, G.N.T. Road, Erukkencherry  
 IND-Chennai-600118  
 Phone +91 44 25372556  
 Fax +91 44 25371149  
 sales@in.ebmpapst.com  
 www.ebmpapst.in

 **Indonesia**  
 ebm-papst Indonesia  
 Representative Office  
 German Centre, 4th Floor, Suite 4470  
 Jl. Kapt. Subijono Dj. Bumi Serpong Damai  
 RI-15321 Tangerang  
 Phone +62 21 5376250  
 Fax +62 21 5388305  
 salesdept@id.ebmpapst.com

 **Israel**  
 Polak Bros. Import Agencies Ltd.  
 9 Hamefalsim Street  
 IL-Kiryat Arie, Petach-Tikva 49514  
 Phone +972 3 9100300  
 Fax +972 3 5796679  
 polak@polak.co.il  
 www.polak.co.il

 **Japan**  
 ebm-papst Industries Japan K.K.  
 12th Floor, Benex S-3 Bldg.  
 3-20-8 Shinyokohama, Kohoku-ku  
 J-222-0033 Yokohama  
 Phone +81 45 47057-51  
 Fax +81 45 47057-52  
 info@jp.ebmpapst.com  
 www.ebmpapst.jp

 **Korea**  
 ebm-papst Korea Co. Ltd.  
 6F, Trutech Bldg.  
 B 6-2, Digital Media City (DMC)  
 Sangam-Dong, Mapo-Gu  
 ROK-Seoul 121-270  
 Phone +82 2 366213-24  
 Fax +82 2 366213-26  
 info@kr.ebmpapst.com  
 www.ebmpapst.co.kr

 **Malaysia**  
 ebm-papst Malaysia  
 Representative Office  
 Unit 12-2, Jalan USJ Sentral 3  
 Persiaran Subang, Selangor Darul Ehsan  
 MAL-47600 Subang Jaya  
 Phone +60 3 8024-1680  
 Fax +60 3 8024-8718  
 salesdept@my.ebmpapst.com

 **Singapore**  
 ebm-papst SEA Pte. Ltd.  
 No. 23 Ubi Road 4  
 #06-00 Olympia Industrial Building  
 SGP-Singapore 408620  
 Phone +65 65513789  
 Fax +65 68428439  
 salesdept@sg.ebmpapst.com

 **Taiwan**  
 ETECO Engineering & Trading Corp.  
 10F-I, No. 92, Teh-Wei Str.  
 RC-Tsow-Inn District, Kaohsiung  
 Phone +886 7 557-4268  
 Fax +886 7 557-2788  
 eteco@ms22.hinet.net  
 www.ebmpapst.com.tw

 **Thailand**  
 ebm-papst Thailand Co., Ltd.  
 99/9 Moo 2, Central Chaengwattana Tower  
 14th Floor, Room 1402  
 Chaengwattana Road Bangtarad, Pakkret  
 THA-11120 Nonthaburi  
 Phone +66 2 8353785-7  
 Fax +66 2 8353788  
 salesdept@th.ebmpapst.com

 **United Arab Emirates**  
 ebm-papst Middle East FZE  
 PO Box 17755  
 Jebel Ali Free Zone / FZS1 / AP05  
 UAE-Dubai  
 Phone +971 4 88608-26  
 Fax +971 4 88608-27  
 info@ae.ebmpapst.com  
 www.ebmpapst.ae

 **Vietnam**  
 ebm-papst Vietnam  
 Representative Office  
 Room #102, 25 Nguyen Van Thu Street  
 District 1  
 VN-Ho Chi Minh City  
 Phone +84 8 39104099  
 Fax +84 8 39103970  
 linh.nguyen@vn.ebmpapst.com

## Australia

---



### Australia

ebm-papst A&NZ Pty Ltd.



10 Oxford Road



AUS-Laverton North, Victoria, 3026

Phone +61 3 9360-6400

Fax +61 3 9360-6464

[sales@ebmpapst.com.au](mailto:sales@ebmpapst.com.au)

[www.ebmpapst.com.au](http://www.ebmpapst.com.au)



### New Zealand

ebm-papst A&NZ Pty Ltd.



102 Henderson Valley Road



NZ-Henderson, Auckland 1230

Phone +64 9 837-1884

Fax +64 9 837-1899

[sales@ebmpapst.com.au](mailto:sales@ebmpapst.com.au)

[www.ebmpapst.com.au](http://www.ebmpapst.com.au)

**ebm-papst**  
**Mulfingen GmbH & Co. KG**

Bachmühle 2  
D-74673 Mulfingen  
Phone +49 7938 81-0  
Fax +49 7938 81-110  
info1@de.ebmpapst.com

**ebm-papst**  
**St. Georgen GmbH & Co. KG**

Hermann-Papst-Straße 1  
D-78112 St. Georgen  
Phone +49 7724 81-0  
Fax +49 7724 81-1309  
info2@de.ebmpapst.com

**ebm-papst**  
**Landshut GmbH**

Hofmark-Aich-Straße 25  
D-84030 Landshut  
Phone +49 871 707-0  
Fax +49 871 707-465  
info3@de.ebmpapst.com

[www.ebmpapst.com](http://www.ebmpapst.com)



**ebmpapst**